



UNITED INTERLOCK® GRATING

United Interlock Plank Grating System from Unistrut, commonly known as Interlock Grating, fills a multitude of needs including flooring and walkways, mezzanines, stair treads, maintenance and staging platforms, scaffolding planks, architectural wall coverings and more. United Interlock Grating Systems meets your needs for strength, durability, safety and aesthetics.



Customers choose United Interlock Grating Systems for many reasons:

- Cost-effectiveness
- Easy-to-install product
- Quality assurance that comes from extensive load testing
- Large inventories and fast delivery
- Strong design look of our plank grating

In addition to supplying the grating, Unistrut offers turnkey service for your project. This includes engineering, support structures, and installation.

United Interlock Grating Applications include:

- Architectural wall coverings
- Catwalks, walkways and pedestrian ramps
- Maintenance and inspection walkways
- Ventilation covers for tanks and wells
- Mining and quarry tower decking
- Pumping and drilling platforms
- Subflooring
- Mezzanines
- Shelving
- Stairs



Ease of Installation	222
Plank Grating	223 - 224
Accessories	225 - 227
Heavy Duty Stair Treads	228
Design and Testing	229
Plank Loads and Deflections	230 - 235
Architectural Specifications.....	236



Architectural Applications

Interlock Grating provides a functional and aesthetically appealing look to architectural applications. Aluminum gratings resist corrosion to give walls, ceilings, ledges, trim, flooring, and specialty projects a clean, lasting, high-tech look.

Interlocking plank grating works especially well in intensive-use areas. In addition to its durability, it is easy to clean and does not reflect sound like a solid surface.

Architects have often selected Interlock Grating because it protects lights, insulation support columns, wiring, and other fixtures. And, the panels allow authorized personnel to access the fixtures.

Contractors have reported installed cost savings of up to 75% with Interlock Grating. Many factors combine to make installation quick and easy:

- 1) The lightweight grating is easy to handle. One person can carry a 24' plank.
- 2) Interlock Grating is easy to install with a minimal number of laborers.
- 3) Interlock Grating's light weight reduces shipping costs.
- 4) The planks interlock with positive friction, eliminating costly welding and bolting.
- 5) Field modifications are easy. Interlock Grating can be cut to size, shape, and angle at the jobsite.
- 6) Interlock Grating requires fewer support structures.



Project Services

United Interlock distribution network provides local support for complete project administration as desired or required by our customers. This includes engineering, design, and installation of all the United Interlock Grating Systems.

Our engineers can design a grating system which will safely span the area using existing supports at your facility, perform load and deflection tests for

unusual loading conditions, advise you of the most economical placement of grating and supports, and provide fabrication and erection drawings.

We can complete your project by coordinating all aspects of installation. Our local distribution network can coordinate shipping and staging of materials, provide and supervise local installation crews, and arrange for special erection equipment services.

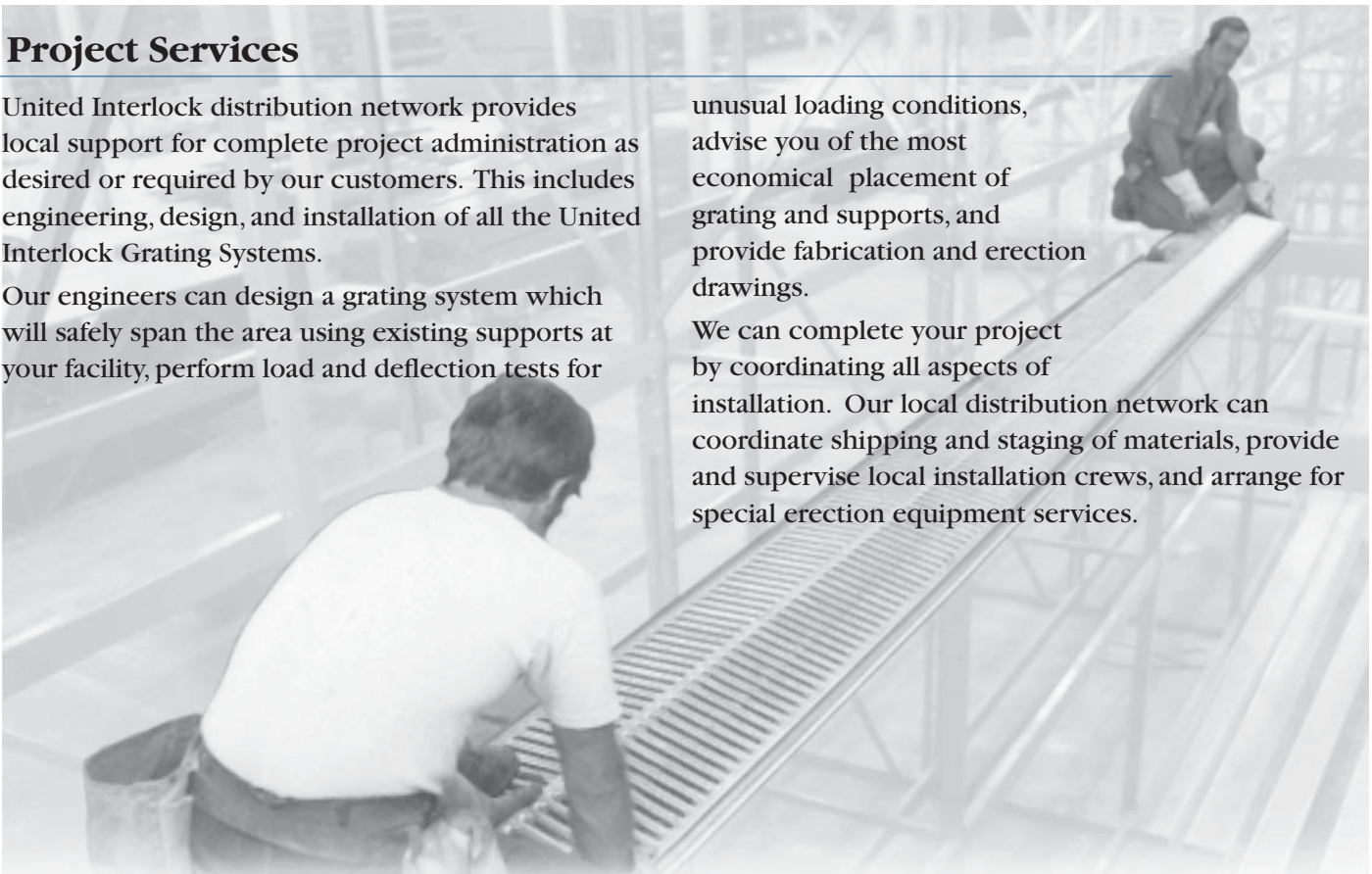

United Interlock Grating strength-to-weight ratio allows it to withstand substantial loads while being easy to handle. The male-female legs of the roll-formed grating interlock securely, and double-male legs provide a safe finished edge for end planks.

Two standard surfaces are available: slotted-smooth and anti-skid. Anti-skid is the ideal choice when safe walking conditions are important. Die-formed teeth in the transverse ribs give you 360° of shoe-gripping traction even when the grating is wet, oily, muddy, or icy.



Interlock Grating Features

Maximizes performance and safety...

- Anti-skid surface provides 360° of slip resistance
- Superior ultimate-load performance tested in accordance with AISI standards
- All sections made from structural-grade steel
- Roll-formed design provides superior strength
- Optional heel-toe side and end plates
- Open design prevents build-up of water, grease, oil and small debris

And gives you complete project versatility.

- 6", 9" and 12" plank widths allow design in 3" increments
- Standard lengths of 20' and 24', and special lengths up to 30', provide excellent design flexibility
- Choice of smooth punched, anti-skid punched or solid unpunched surfaces
- Three leg heights, and two material gauges meet a wide range of load, space and budget requirements

Punched Interlock Grating has an open area of 42% for 9" grating and 35% for 6" grating. This prevents dirt, debris, ice, and snow from building up on the surface and allows light and air to pass through. United Interlock steel grating is made from pre-galvanized steel which conforms to a G-90 thickness designation per ASTM A653. The aluminum grating is made from type 5052 aluminum with a thickness of 0.080".

Unpunched smooth surface grating is also available for special applications.

United Interlock Grating Systems are strong, economical, versatile, and easy to specify.

Variety of choices

- 6" and 9" standard-duty width
- 12" light-duty width
- 14 gauge and 18 gauge
- 1½", 2½", and 4" leg heights
- 20' and 24' stock lengths
- Anti-skid, slotted-smooth punched surfaces and solid unpunched surface
- Double male and male-female leg shapes
- Steel (6", 9" or 12") and aluminum (6" or 9")

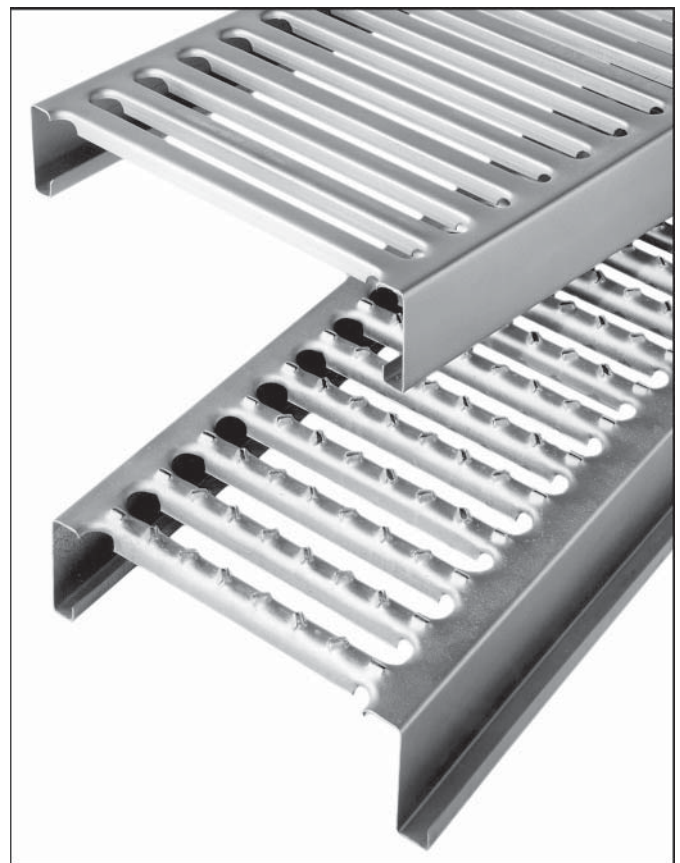



UNITED INTERLOCK® GRATING SYSTEMS—6" AND 9"

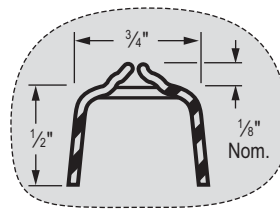
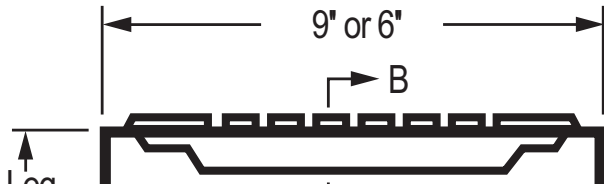

Anti-skid Rib

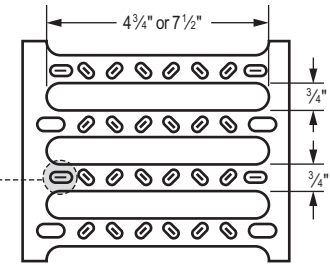

Anti-skid Surface Shown

9" Wide Planks (14 Ga, 18 Ga, 0.080 Aluminum)							
Leg Height	Leg Shape	Finish Material	Slotted, Smooth	Anti-Skid	Un-punched	Wt. Lbs./Ft	Wt. Lbs./Ft ²
1 1/2"	DM	PG	G91141	G91142	G91143	3.5	4.7
	MF	14 Ga.	G92141	G92142	G92143	3.5	4.7
	DM	PG	G91181	G91182	G91183	2.3	3.1
	MF	18 Ga.	G92181	G92182	G92183	2.3	3.1
2 1/2"	DM	PG	G91241	G91242	G91243	4.0	5.3
	MF	14 Ga.	G92241	G92242	G92243	4.0	5.3
	DM	PG	G91281	G91282	G91283	2.7	3.6
	MF	18 Ga.	G92281	G92282	G92283	2.7	3.6
	DM	AL	G91221	G91222	G91223	1.5	2.0
	MF	0.080"	G92221	G92222	G92223	1.5	2.0
4"	DM	PG	G91341	G91342	G91343	4.8	6.4
	MF	14 Ga.	G92341	G92342	G92343	4.8	6.4
	DM	PG	G91381	G91382	G91383	3.2	4.3
	MF	18 Ga.	G92381	G92382	G92383	3.2	4.3

6" Wide Planks (14 Ga, 18 Ga, 0.080 Aluminum)							
Leg Height	Leg Shape	Finish Material	Slotted, Smooth	Anti-Skid	Un-punched	Wt. Lbs./Ft	Wt. Lbs./Ft ²
1 1/2"	DM	PG	G61141	G61142	G61143	2.7	5.4
	MF	14 Ga.	G62141	G62142	G62143	2.7	5.4
	DM	PG	G61181	G61182	G61183	1.8	3.6
	MF	18 Ga.	G62181	G62182	G62183	1.8	3.6
2 1/2"	DM	PG	G61241	G61242	G61243	3.4	6.8
	MF	14 Ga.	G62241	G62242	G62243	3.4	6.8
	DM	PG	G61281	G61282	G61283	2.2	4.4
	MF	18 Ga.	G62281	G62282	G62283	2.2	4.4
	DM	AL	G61221	G61222	G61223	1.2	2.3
	MF	0.080"	G62221	G62222	G62223	1.2	2.3
4"	DM	PG	G61341	G61342	G61343	4.2	8.4
	MF	14 Ga.	G62341	G62342	G62343	4.2	8.4
	DM	PG	G61381	G61382	G61383	2.8	5.6
	MF	18 Ga.	G62381	G62382	G62383	2.8	5.6

Note: Standard grating lengths are 20' or 24'; DM=Double Male, MF=Male-Female
Unpunched smooth surface grating is also available for special applications. Contact Unistrut for more information.

UNITED INTERLOCK® GRATING SYSTEMS—12"

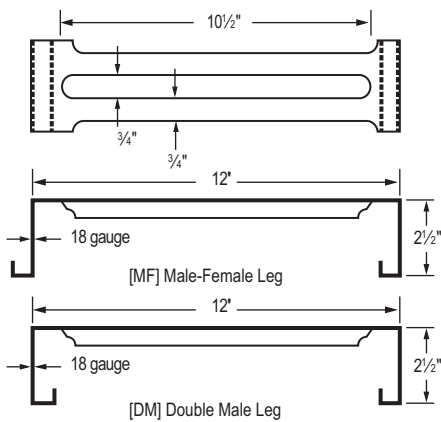

12" Wide Planks, 18 Gauge				
Leg Height	Leg Shape	Finish Material	Slotted, Smooth	Anti-Skid
2 1/2"	DM	PG	G 11281	G 11282
	MF	18 Gauge	G 12281	G 12282

For Light Traffic Applications

Ideal for mezzanines and other large-area applications, extra-wide 12" interlocking plank grating is designed to simplify installation and reduce the cost of mezzanines, flooring, decking, staging platforms, Roofwalks® and similar applications. With a 43% open area, it allows water, light and air to pass through.

With its extra width, Unistrut 12" wide plank grating covers more area with fewer planks, lowering installation costs. Its high strength-to-weight ratio—18 gauge, 2 1/2" leg height—makes it ideal for covering large, light-traffic areas. Its snap-together friction fit make it easy to install, with no welding or bolting required.

Made of pre-galvanized steel, it's maintenance-free and long lasting. Specifiers can choose a smooth or anti-skid surface to meet a wide variety of application needs.

FILLER PANEL

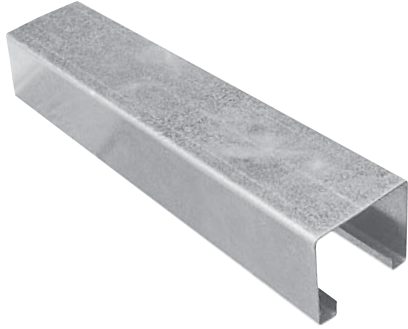

Part No.*	Description
G31183 PG	3" Wide x 1½" Leg Height
G31283 PG	3" Wide x 2½" Leg Height
G31383 PG	3" Wide x 4" Leg Height

Provided in standard lengths of 10' and 12'.

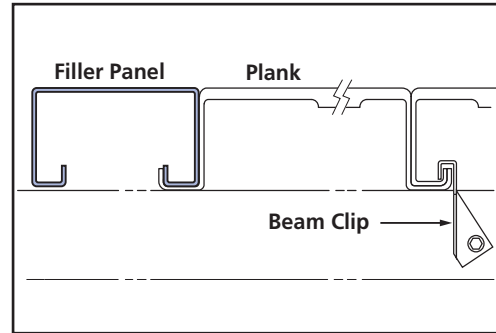

CARRIER PLATE



Part No.*	Description
G603 PG	10 ga. - for 9" wide heavy duty stair treads (⅜" hole and 1½" x ⅜" slot)
G618 PG	10 ga. for 10½" wide stair treads (⅜" hole and 1½" x ⅜" slot)
G642 PG	10 ga. for 11" wide stair treads (⅜" hole and 1½" x ⅜" slot)

Provides easy attachment of stair treads to support structures and stringers.

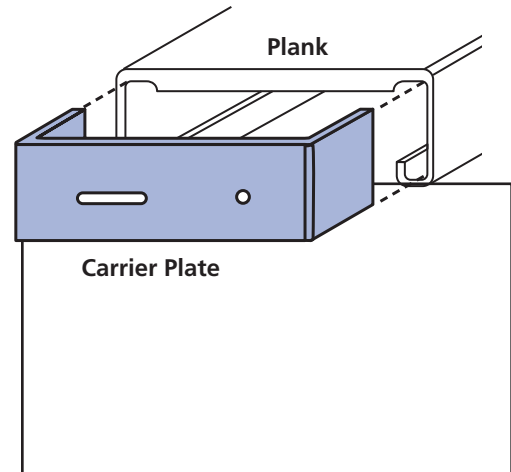

HEEL/TOE SIDE PLATES – 6½" AND 8" HEIGHTS



Part No.*	Description
G631 PG	14 ga. x 6½" high x 12' long
G621 PG	14 ga. x 8" high x 12' long

Forms a curb along grating length that defines a structure's side edge, and helps contain loose objects.

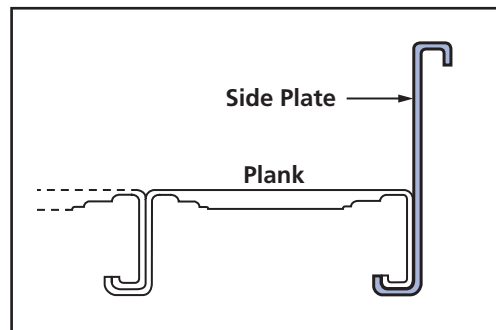

*Part numbers shown are for galvanized. Most accessories are also available in aluminum.



HEEL/TOE END PLATES – 6½" AND 8" HEIGHTS

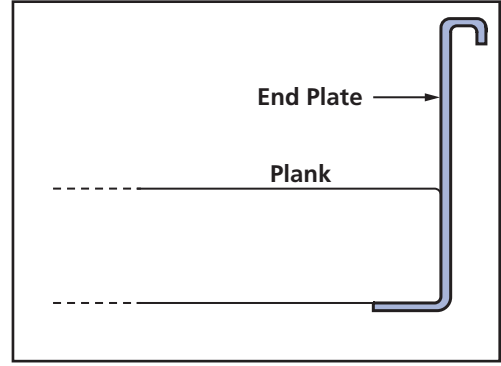
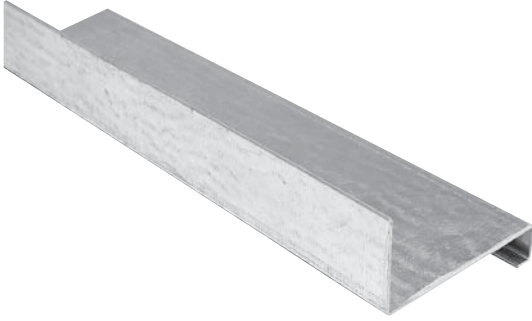

Part No.*	Description
G622 PG	14 ga. x 6½" high x 12' long
G623 PG	14 ga. x 8" high x 12' long

Forms a curb along grating ends that defines a structure's edge, and helps contain loose objects.

HOLD DOWN CLIP



Part No.*	Description
G639 PG	1½" leg height
G607 PG	2½" leg height
G620 PG	4" leg height

A 16 gauge attachment for fastening grating to support structure below. Attaches through top side of grating.

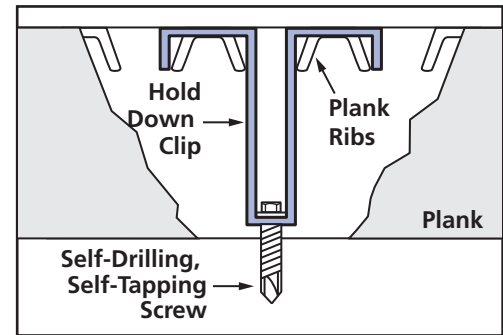

"J" BOLT/NUT LOCK WASHER



Part No.*	Description
G600 EG	⅝" x 2½"

Attachment for fastening panels to supporting members from underside of grating.

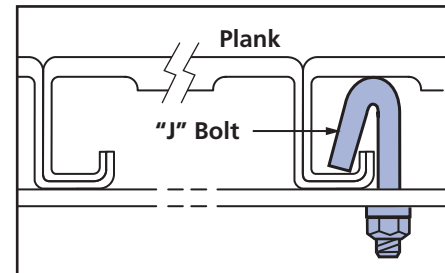

*Part numbers shown are for galvanized. Most accessories are also available in aluminum.

GRATING BEAM CLAMP



Part No.*	Description
G640 EG	Beam clamp

Attaches grating to structural I-beams. Requires no welding or drilling.

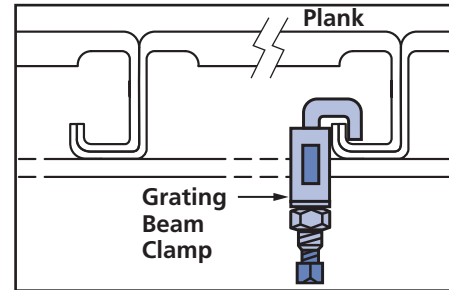

LIGHT GAUGE BEAM CLIP



Part No.*	Description
G124 EG	Light Gauge Beam Clip

Quickly attaches grating to rack or shelving beams. Requires self-drilling, self-tapping screw—GHTS 012075 EG (not included).

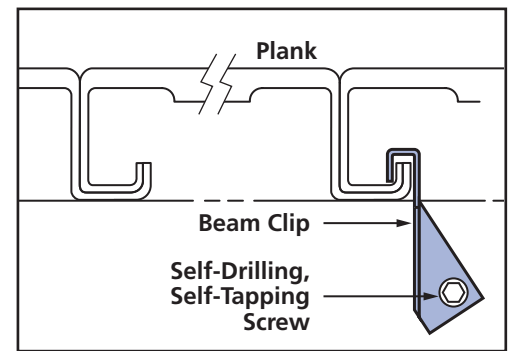

RECESSED WASHER



Part No.*	Description
G714 EG	1 1/8" x 1 1/8" 12 gauge square washer

Holds down grating from above. Eliminates trip points.

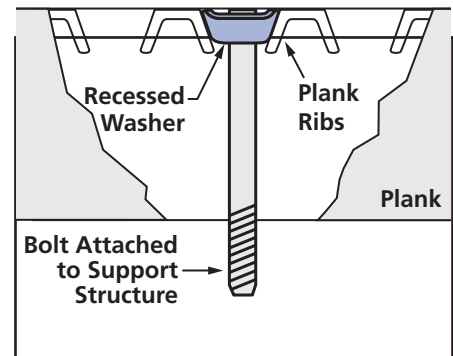

*Part numbers shown are for galvanized. Most accessories are also available in aluminum.



1 1/2" System

1 1/4" System

1 3/16" System

Fiberglass System

Special Metals

Prime Angle

Metal Grating

Roofwalk

Index

Anyone who has slipped on a stairway can appreciate the safety of the anti-skid stair treads. Those who have tried to clean solid-surface stairs can appreciate our maintenance-free slotted design, which is both rust-resistant and self-cleaning.

United's stair treads make it easy for you to meet OSHA regulations. Factors to consider when selecting stair treads include loads, impact, frequency of



use, and future use. Our 10 1/2" and 11" tread features a checker-plate nosing that strengthens the tread and increases the width of the basic 9" tread.

The failure loading data shown below indicates ultimate failure in pounds at various spans. A 3 1/2" diameter load was applied to the outer edge of a 9" wide stair tread at the center of the span. 6" wide stair treads are also available.

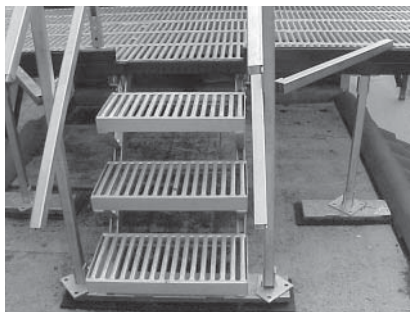

The stair treads can also be used with Unistrut Metal Framing as shown here to create a stair with guide rail

9" Stair Tread

14 gauge x 2 1/2" x 9"
Completely galvanized,
welded 10 gauge
end plates



Part No.*	Length (in.)
G 900-24 PG	24
G 900-30 PG	30
G 900-36 PG	36
G 900-42 PG	42
G 900-48 PG	48
G 900-60 PG	60

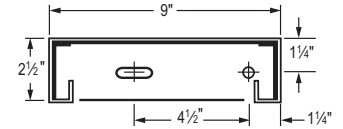

10 1/2" Stair Tread

14 gauge x 2 1/2" x 10 1/2",
Completely galvanized,
welded 10 gauge end plates



Part No.*	Len. (in.)
G 901-24 PG	24
G 901-30 PG	30
G 901-36 PG	36
G 901-42 PG	42
G 901-48 PG	48
G 901-60 PG	60

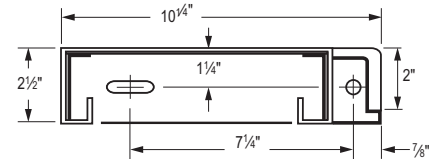

11" Stair Treads

14 gauge x 2 1/2" x 11" Completely galvanized, welded
10-gauge end plates

Part No.*	Len. (in.)
G 904-24 PG	24
G 904-30 PG	30
G 904-36 PG	36
G 904-42 PG	42
G 904-48 PG	48
G 904-54 PG	54
G 904-60 PG	60

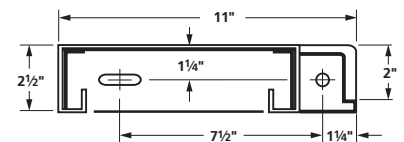

Ultimate Failure Loading (pounds): Interlock Grating Stair Treads—Galvanized Steel—3 Widths									
Width	Distance Between Supports (feet)								
	2	2.5	3	3.5	4	4.5	5	5.5	6
9"	2,200	2,050	1,900	1,750	1,600	1,450	1,300	1,150	1,000
10 1/2"	4,325	3,900	3,400	2,950	2,550	2,200	1,950	1,800	1,700
11"	4,325	3,900	3,400	2,950	2,550	2,200	1,950	1,800	1,700

Note: This table represents failure loads, not design loads. Designers should apply their own safety factor to these values to determine maximum design loads.

Design Considerations

Designers must consider both uniform and concentrated loads. Design considerations are most critical where loads are concentrated on a small area. As the area of the application gets larger, the reactions approach those of uniform loads.

Although a plank of grating may take a considerable allowable load, there may be more deflection than the designer feels is comfortable for foot traffic. We believe dividing the number of inches in the span length by 240 produces a reasonable deflection.

Designing for overloads and future usage is generally a wise investment considering the costs of future maintenance, obsolescence and replacement, as well as the danger of accidents.

Point (Concentrated) Loads

Point loads should be distributed over a minimum of two transverse ribs, regardless of what size or gauge plank grating is utilized.

Good design practice for point loading plank grating employs a “foot” plate at the load point with a minimum dimension of 3" x 3". This plate will assure that the point load has been distributed over the two transverse-rib minimum.

Maximum point load per rib on 12" x 18 ga. steel plank grating is 185 lbs. As a result, through the use of the required 3" x 3" “foot” plate, a maximum design load for the minimum-dimension foot plate is 370 lbs. Higher loads can be supported by the transverse ribs. However, larger “foot” plates will then be required to distribute the higher loads over additional ribs.

Light Traffic Areas

Floor areas immediately adjacent to racks, shelves, conveyors, etc., are generally loaded by light traffic. Ends of aisles, single aisles, etc. are further examples of light-traffic areas. These and similar areas are satisfactorily covered by economical 12" grating.

Floor area beneath package conveyors or other material-handling devices are typically subject to little or no loading. However, for safety reasons, these areas must be covered. The use of 12" plank grating in these areas provides an economical floor covering that can also be used as a load-bearing floor if requirements change.

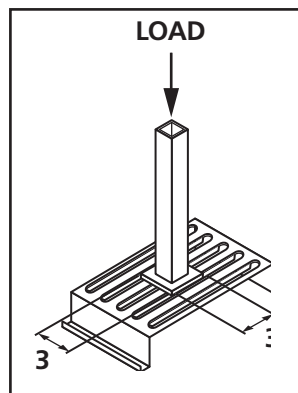

12" Plank Grating is designed to provide an economical lightweight floor surface for light-traffic areas. Maintenance platforms, access ways and rooftop walkway applications are examples of areas where 12" grating is the best economical choice.

High-Traffic Areas

Mezzanines and aisles for stock storage are typical high-traffic zones. As a result, grating in these areas must have higher fatigue strengths. High fatigue strengths are available utilizing narrow, high-strength 6" or mid-range 9" width grating.

Within these high traffic areas are floor sections that receive little or no traffic, but must be covered for safety reasons. Innovative designers employ 12" grating in this situation. Combining 12" grating with other grating widths and gauges lowers overall installed costs for high-traffic applications.

Testing

Unistrut is dedicated to the research, development and testing of all our manufactured products. The United Interlock Grating System has been tested in accordance with section 6 of the American Iron and Steel Institute's (AISI) Specifications for the Design of Cold Formed Steel Structural Members.

Tests for allowable loads were performed on product randomly selected from stock. These tests were run on simple spans with no end restrictions, over a 2" end bearing. Concentrated loads were applied across the plank with a 3" bearing, while uniform loads were applied by stacking narrow strips of sheet steel uniformly over the plank surface. Concentrated load tests for galvanized steel grating were run on all strength combinations for spans of 2', 3', 4', 5', 6', 7', 8', 10', 12', 14', 16' and 18'. Uniform load tests for galvanized steel were run on spans of 2', 3', 4', 6', 8' and 10'.

Concentrated load results are the same for 6" and 9" wide planks.

Allowable concentrated loads are found by reducing the ultimate load by 1/2 times the weight of the grating and dividing the remaining load by two. This gives a safety factor of 2. Allowable uniform loads were calculated by standard formulas from the results found in the concentrated load tests.

1 1/2" System

1 1/4" System

1 3/16" System

Fiberglass System

Special Metals

Prime Angle

Metal Grating

Roofwalk

Index

Leg Height	Codes	Distance Between Supports (Feet)															
		2	2.5	3	3.5	4	4.5	5	5.5	6	6.5	7	8	9	10	12	14
1 1/2"	UL	1,232	788	548	402	293	204	150	113	86	68	54	-	-	-	-	-
	UD	0.05	0.08	0.12	0.16	0.20	0.22	0.25	0.27	0.30	0.32	0.35	-	-	-	-	-
	CL	616	493	411	352	308	274	234	193	162	138	119	-	-	-	-	-
	CD	0.04	0.06	0.10	0.13	0.17	0.21	0.25	0.27	0.30	0.32	0.35	-	-	-	-	-
2 1/2"	UL	4,886	3,296	2,150	1,601	1,257	924	734	597	501	431	369	263	204	150	84	47
	UD	0.15	0.17	0.18	0.22	0.26	0.36	0.41	0.45	0.47	0.52	0.61	0.81	0.89	1.13	1.33	1.42
	CL	2,443	2,060	1,612	1,400	1,257	1,040	917	820	752	700	647	525	460	374	250	165
	CD	0.17	0.17	0.17	0.20	0.22	0.25	0.29	0.34	0.40	0.46	0.55	0.66	0.79	0.90	1.07	1.18
4"	UL	5,261	4,016	3,147	2,321	1,755	1,520	1,307	1,019	858	738	648	548	420	342	215	165
	UD	0.08	0.10	0.11	0.13	0.16	0.16	0.17	0.23	0.27	0.33	0.40	0.52	0.65	0.82	1.07	1.18
	CL	2,630	2,510	2,360	2,080	1,755	1,710	1,633	1,400	1,288	1,200	1,134	1,094	980	854	643	577
	CD	0.13	0.14	0.15	0.17	0.18	0.19	0.20	0.23	0.26	0.30	0.33	0.45	0.57	0.69	0.91	1.26

Leg Height	Codes	Distance Between Supports (Feet)															
		2	2.5	3	3.5	4	4.5	5	5.5	6	6.5	7	8	9	10	12	14
1 1/2"	UL	858	548	380	281	204	144	104	78	60	48	38	-	-	-	-	-
	UD	0.05	0.08	0.12	0.16	0.20	0.22	0.25	0.27	0.30	0.32	0.35	-	-	-	-	-
	CL	429	343	286	245	214	190	163	135	113	96	83	-	-	-	-	-
	CD	0.04	0.06	0.10	0.13	0.17	0.21	0.25	0.27	0.30	0.32	0.35	-	-	-	-	-
2 1/2"	UL	2,472	1,664	1,220	881	663	516	414	342	284	237	197	164	134	102	66	41
	UD	0.14	0.15	0.16	0.21	0.26	0.31	0.36	0.38	0.44	0.47	0.49	0.79	0.89	1.12	1.37	1.58
	CL	1,236	1,040	915	770	663	580	518	470	426	385	344	327	300	255	200	140
	CD	0.12	0.14	0.16	0.18	0.21	0.24	0.28	0.29	0.30	0.37	0.46	0.61	0.74	0.91	1.20	1.50
4"	UL	3,296	2,544	2,010	1,520	1,179	947	744	626	522	449	402	314	249	191	147	101
	UD	0.12	0.13	0.14	0.15	0.15	0.21	0.26	0.29	0.31	0.35	0.42	0.58	0.59	0.70	0.81	0.89
	CL	1,648	1,590	1,507	1,330	1,179	1,065	930	860	783	730	704	628	560	477	440	350
	CD	0.11	0.12	0.13	0.14	0.14	0.17	0.18	0.22	0.26	0.28	0.32	0.39	0.48	0.51	0.88	1.07

Leg Height	Codes	Distance Between Supports (Feet)															
		2	2.5	3	3.5	4	4.5	5	5.5	6	6.5	7	7.5	8	9	10	
2 1/2"	UL	2,676	1,590	1,065	840	706	600	517	412	313	277	255	210	177	-	-	
	UD	0.20	0.30	0.35	0.40	0.47	0.55	0.63	0.78	1.01	1.09	1.20	1.4	1.66	-	-	
	CL	1,338	925	825	755	706	630	575	515	469	435	410	385	355	-	-	
	CD	0.16	0.20	0.25	0.31	0.36	0.45	0.54	0.67	0.81	0.90	0.99	1.12	1.27	-	-	

Code Key: UL = Uniform Load (pounds per square foot)
 UD = Deflection under uniform load (Inches)
 CL = Concentrated Load (pounds)
 CD = Deflection under concentrated load (Inches)

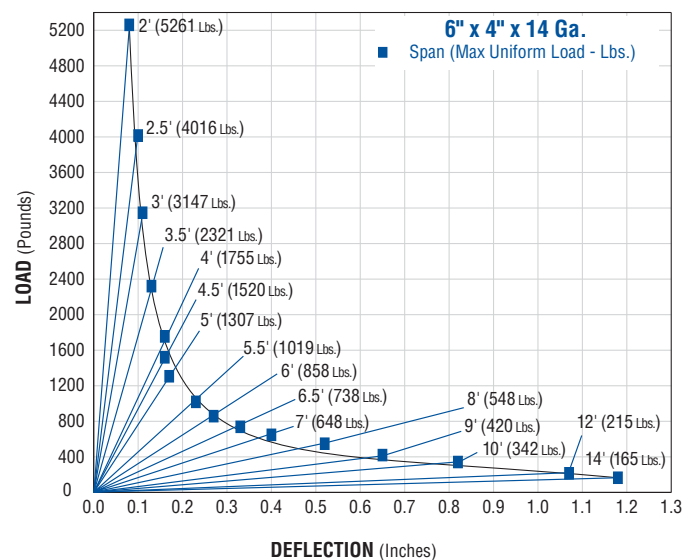
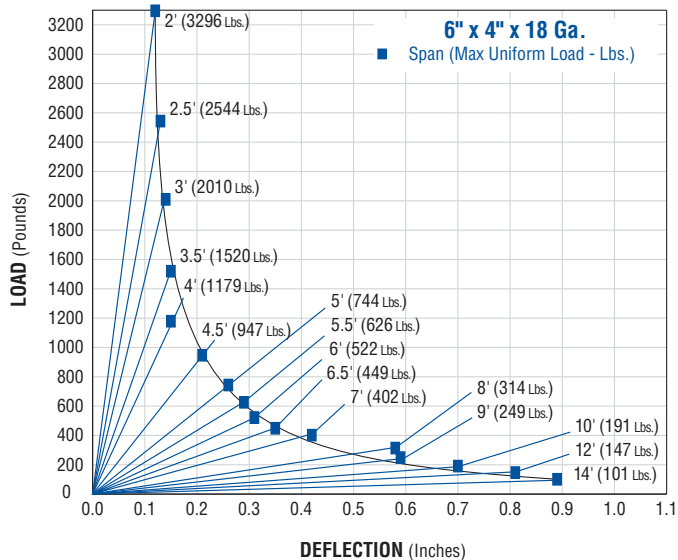
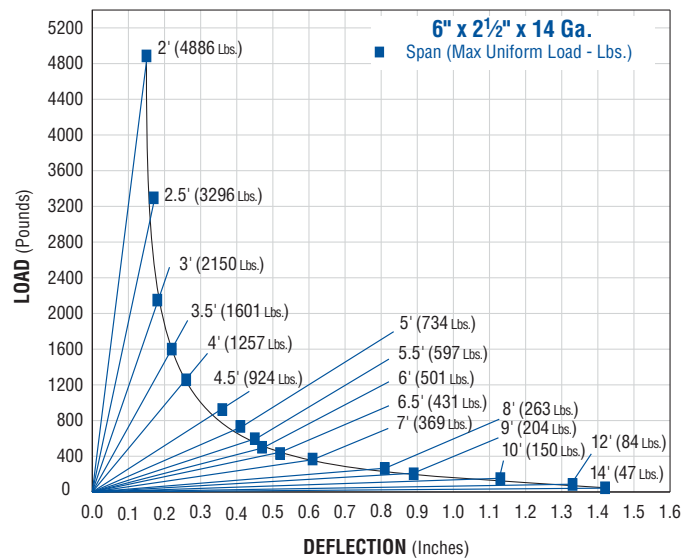
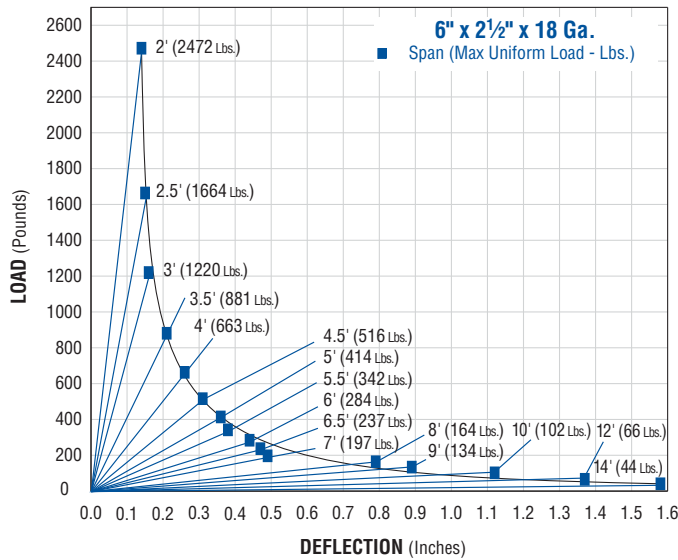
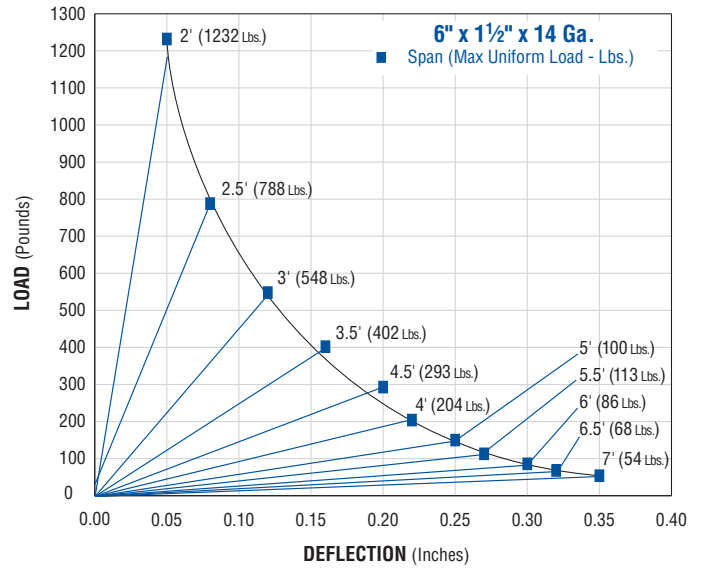
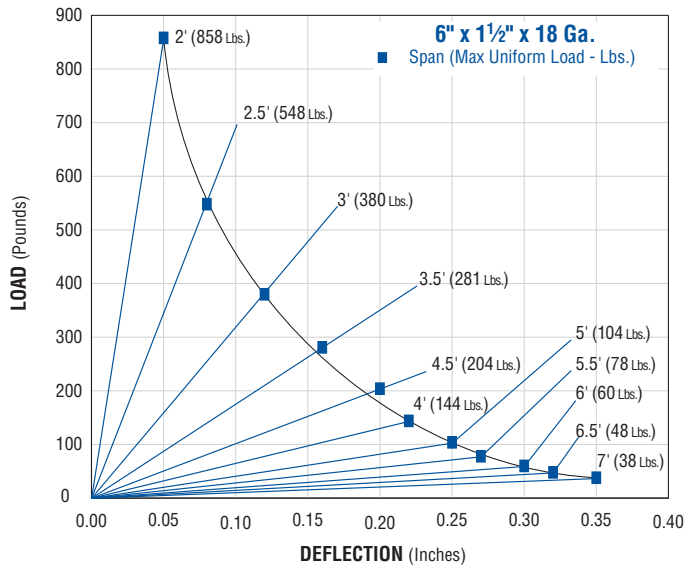



1 1/2" System
1 1/4" System
1 3/16" System
Fiberglass System
Special Metals
Prime Angle
Metal Grating
Roofwalk
Index

9" x 14 Gauge	Leg Height	Codes	Distance Between Supports (Feet)															
			2	2.5	3	3.5	4	4.5	5	5.5	6	6.5	7	8	9	10	12	14
1 1/2"	UL	UD	821	525	365	268	195	136	100	75	57	45	36	-	-	-	-	-
		CL	0.05	0.08	0.12	0.16	0.20	0.22	0.25	0.27	0.30	0.32	0.35	-	-	-	-	-
		CD	616	493	411	352	308	274	234	193	162	138	119	-	-	-	-	-
		UD	0.04	0.06	0.10	0.13	0.17	0.21	0.25	0.27	0.30	0.32	0.35	-	-	-	-	-
2 1/2"	UL	UD	3,257	2,197	1,433	1,067	838	616	489	398	334	287	246	175	136	100	56	31
		CL	0.15	0.17	0.18	0.22	0.26	0.36	0.41	0.45	0.47	0.52	0.61	0.81	0.89	1.13	1.33	1.42
		CD	2,443	2,060	1,612	1,400	1,257	1,040	917	820	752	700	647	525	460	374	250	165
		UD	0.17	0.17	0.17	0.20	0.22	0.25	0.29	0.34	0.40	0.46	0.55	0.66	0.79	0.90	1.07	1.18
4"	UL	UD	3,507	2,677	2,098	1,547	1,170	1,013	871	679	572	492	432	365	280	228	143	110
		CL	0.08	0.10	0.11	0.13	0.16	0.16	0.17	0.23	0.27	0.33	0.40	0.52	0.65	0.82	1.07	1.18
		CD	2,630	2,510	2,360	2,080	1,755	1,710	1,633	1,400	1,288	1,200	1,134	1,094	980	854	643	577
		UD	0.13	0.14	0.15	0.17	0.18	0.19	0.20	0.23	0.26	0.30	0.33	0.45	0.57	0.69	0.91	1.26

9" x 18 Gauge	Leg Height	Codes	Distance Between Supports (Feet)															
			2	2.5	3	3.5	4	4.5	5	5.5	6	6.5	7	8	9	10	12	14
1 1/2"	UL	UD	572	365	253	187	136	96	69	52	40	32	25	-	-	-	-	-
		CL	0.05	0.08	0.12	0.16	0.20	0.22	0.25	0.27	0.30	0.32	0.35	-	-	-	-	-
		CD	429	343	286	245	214	190	163	135	113	96	83	-	-	-	-	-
		UD	0.04	0.06	0.10	0.13	0.17	0.21	0.25	0.27	0.30	0.32	0.35	-	-	-	-	-
2 1/2"	UL	UD	1,648	1,109	813	587	442	344	276	228	189	158	131	109	89	68	44	27
		CL	0.14	0.15	0.16	0.21	0.26	0.31	0.36	0.38	0.44	0.47	0.49	0.79	0.89	1.12	1.37	1.58
		CD	1,236	1,040	915	770	663	580	518	470	426	385	344	327	300	255	200	140
		UD	0.12	0.14	0.16	0.18	0.21	0.24	0.28	0.29	0.30	0.37	0.46	0.61	0.74	0.91	1.2	1.5
4"	UL	UD	2,197	1,696	1,340	1,013	786	631	496	417	348	299	268	209	166	127	98	67
		CL	0.12	0.13	0.14	0.15	0.15	0.21	0.26	0.29	0.31	0.35	0.42	0.58	0.59	0.70	0.81	0.89
		CD	1,648	1,590	1,507	1,330	1,179	1,065	930	860	783	730	704	628	560	477	440	350
		UD	0.11	0.12	0.13	0.14	0.14	0.17	0.18	0.22	0.26	0.28	0.32	0.39	0.48	0.51	0.88	1.07

9" Aluminum (0.080)	Leg Height	Codes	Distance Between Supports (Feet)												
			2	2.5	3	3.5	4	4.5	5	5.5	6	6.5	7	7.5	8
2 1/2"	UL	UD	1,784	1,060	710	560	471	400	345	275	209	185	170	140	118
		CL	0.20	0.30	0.35	0.40	0.47	0.55	0.63	0.78	1.01	1.09	1.20	1.4	1.66
		CD	1,338	925	825	755	706	630	575	515	469	435	410	385	355
		UD	0.16	0.20	0.25	0.31	0.36	0.45	0.54	0.67	0.81	0.90	0.99	1.12	1.27

Code Key: UL = Uniform Load (pounds per square foot)
 UD = Deflection under uniform load (Inches)
 CL = Concentrated Load (pounds)
 CD = Deflection under concentrated load (Inches)

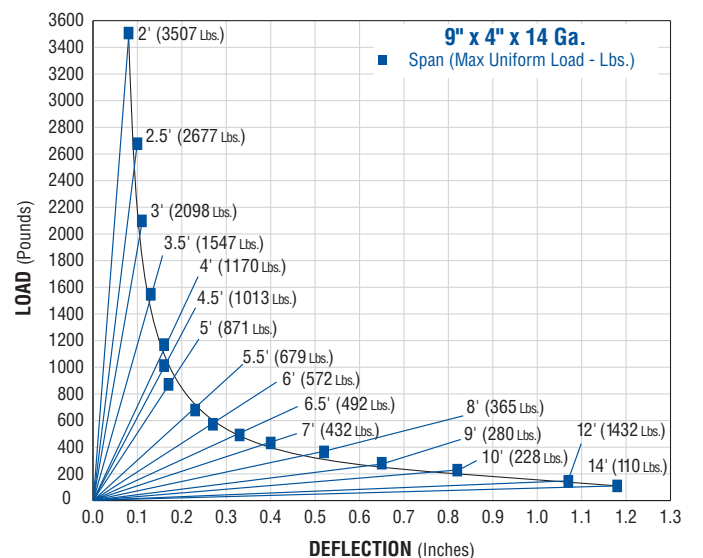
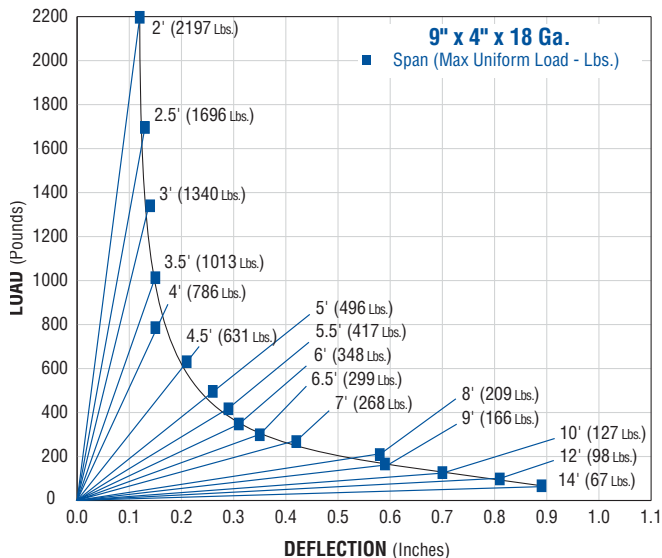
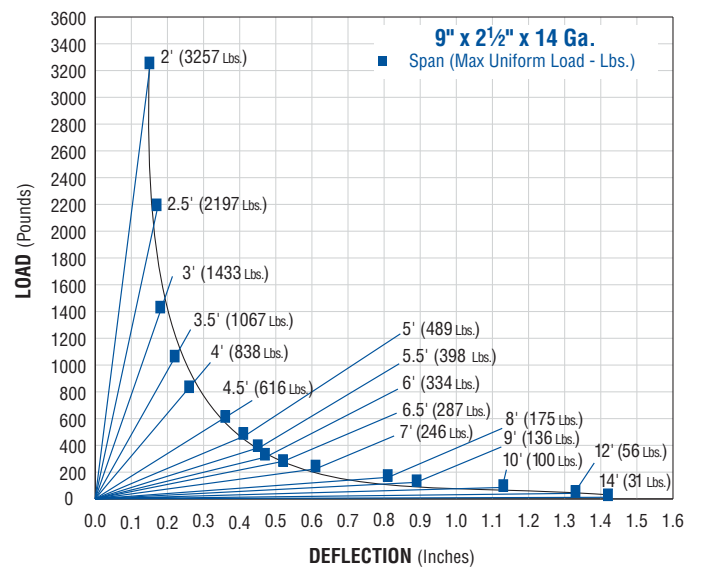
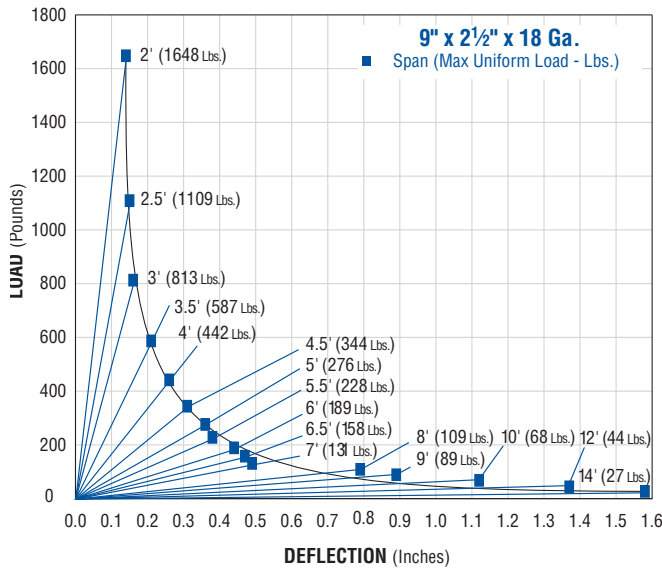
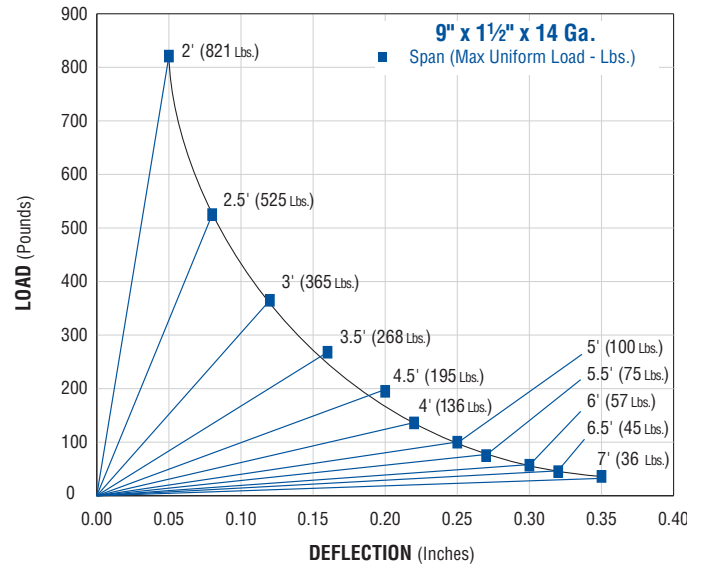
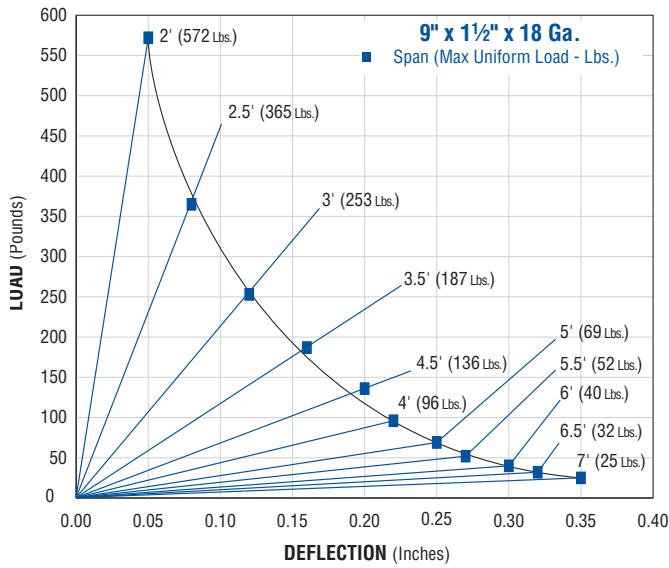



1 1/2" System
1 1/4" System
1 3/16" System
Fiberglass System
Special Metals
Prime Angle
Metal Grating
Roofwalk
Index

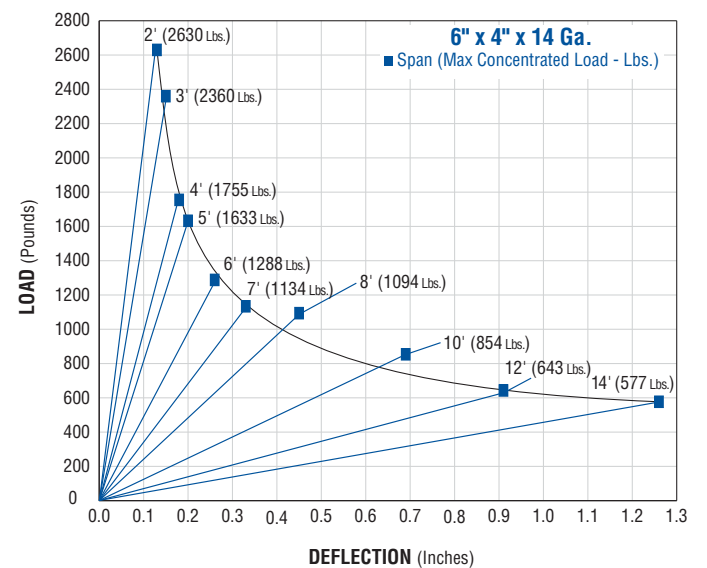
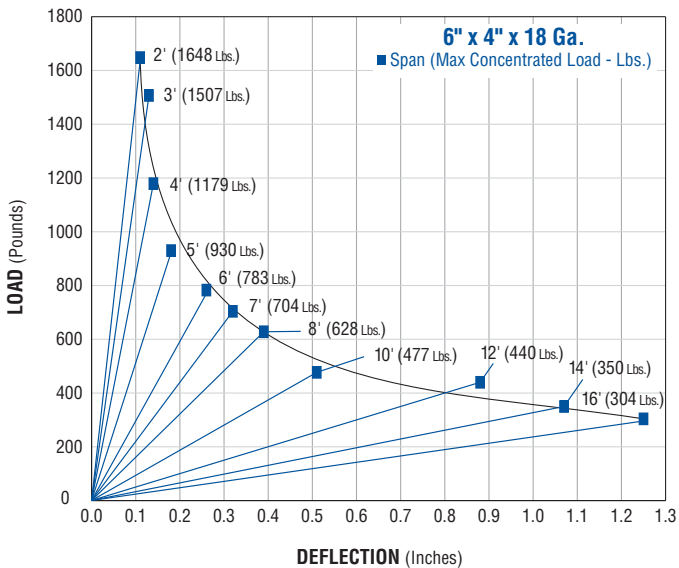
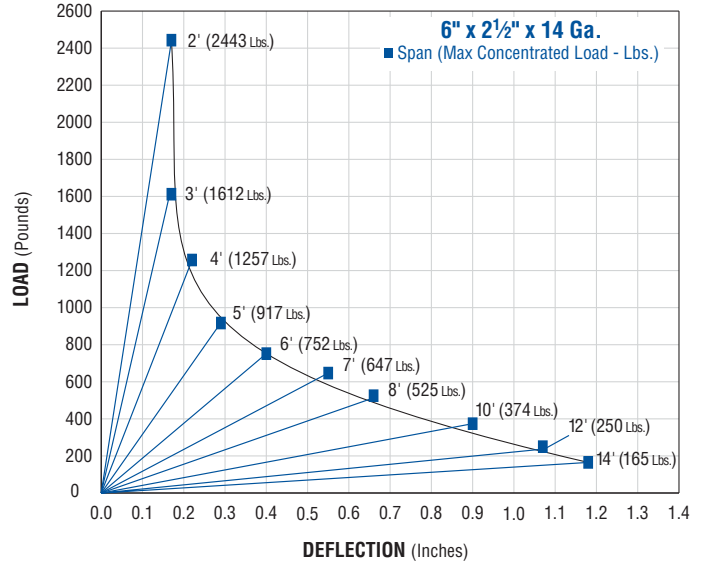
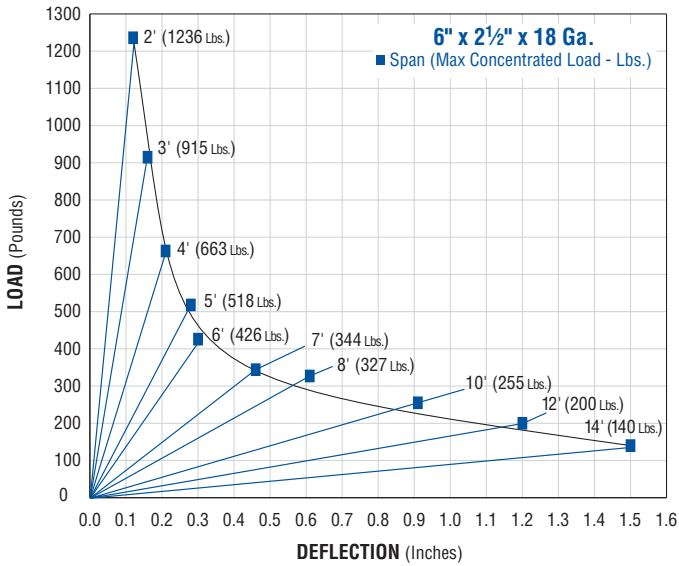
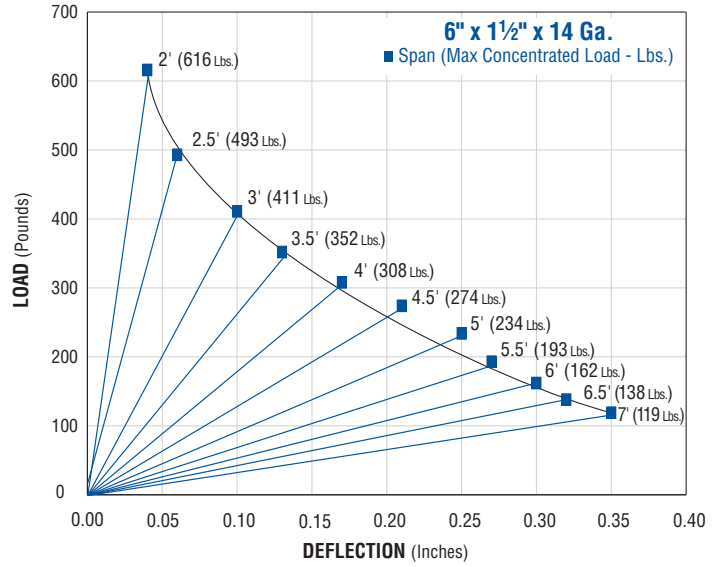
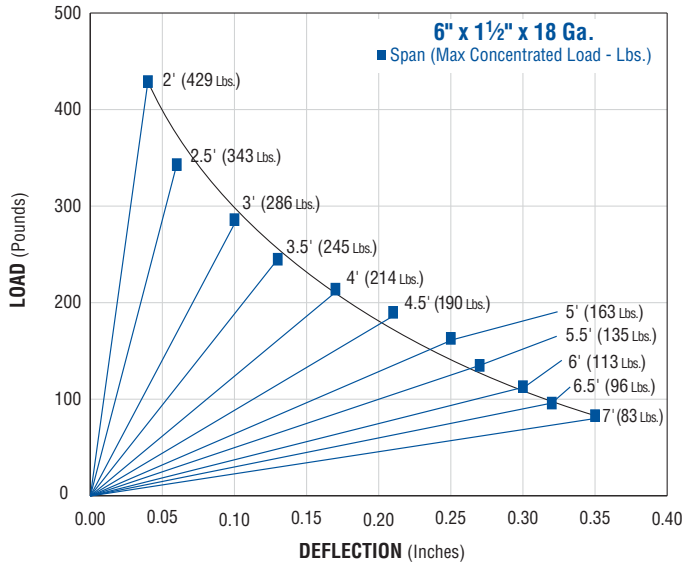

12" x 18 Gauge	Leg Height	Codes	Distance Between Supports (Feet)														
			2	2.5	3	3.5	4	4.5	5	5.5	6	6.5	7	7.5	8	9	10
2 1/2"	UL		750	600	500	370	285	225	180	150	127	-	-	-	-	-	-
	UD		0.04	0.07	0.11	0.16	0.20	0.25	0.31	0.37	0.44	-	-	-	-	-	-
	CL		560	560	560	560	560	500	455	415	380	-	-	-	-	-	-
	CD		0.02	0.04	0.07	0.11	0.16	0.20	0.25	0.30	0.35	-	-	-	-	-	-

Code Key: UL = Uniform Load (pounds per square foot)
 UD = Deflection under uniform load (Inches)
 CL = Concentrated Load (pounds)
 CD = Deflection under concentrated load (Inches)

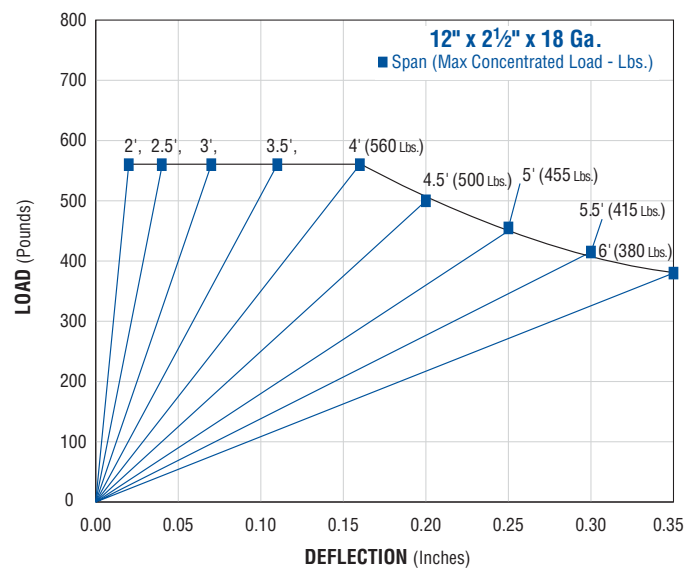
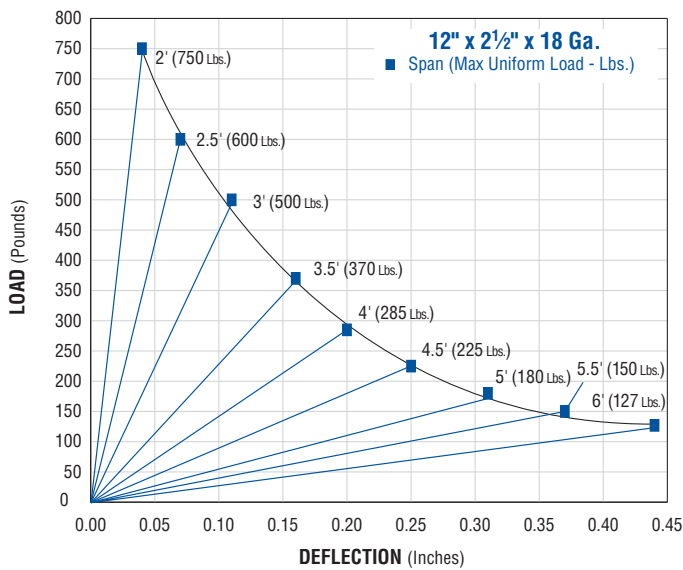



1. GENERAL

1.1 Scope of Work

- A. Provide all material and labor required for the interlocking plank grating as indicated in the contract documents.

1.2 Related Work Specified Elsewhere

- A. Structural Steel
B. Cold Formed Metal Framing
C. Metal Fabrications

1.3 Quality Assurance

- A. Material shall be provided by a qualified contractor with at least five (5) years experience in the manufacture of interlock grating. Contractor shall demonstrate experience in projects of similar scope.
- B. Anti-Skid surfaced grating shall conform to Federal Specification RR-G-1602A.
- C. The Grating shall be designed to withstand the following load criteria:
1. Uniform Live Load _____ psf.
 2. Concentrated Load _____ lbs.
- D. Contractor shall certify that grating has been tested, indicating maximum allowable uniform and concentrated loads, with a factor of safety of 2, per AISC, Section 6.
- E. If product is required in nuclear and/or safety related application, it shall be supplied under the requirements of nuclear specification 10CFR 50 appendix B.

1.4 Submittals

- A. Contractor shall submit shop drawings showing grating layout, support structure and detailed sections depicting assembly.

2. PRODUCTS

2.1 Acceptable Manufacturer

- A. In order to define the requirements for quality, function, sizes, gauges, surfaces, etc., these material specifications designate manufacturers, brands and other pertinent data that describe the minimum product standards of the products that conform to the project's requirements.
- B. Products of other manufacturers may also be acceptable, provided that such products are equivalent to, or better than, those specified and, further, that use of such substitute products will not involve additional cost to owner due to possible required changes to accommodate them.

- C. The alternate (substitute) product must be a proven equivalent to that specified by submitting technical data, test reports, samples, typical details, comparative layout and engineering calculations for evaluation.
- D. The acceptance of an alternate (substitute) product is at the discretion of the owner or his agents, whose decision shall be final.

2.2 Products

- A. Grating shall be United Interlock Plank Grating System, as manufactured by Unistrut, 16100 S. Lathrop Ave., Harvey, IL 60426 (U.S.A.), Phone (800) 882-5543.
- B. Materials shall conform to ASTM A653, Grade A with a Class G-90 coating.
- C. Material shall be _____ gauge. With a leg height of _____ inches.
- D. The surface pattern shall provide a minimum of 35% but not more than 42% open area. Openings shall be a minimum of 4" long and a maximum of 3/4" width. The surface shall be _____.
1. Anti-Skid surface shall provide 360° positive traction and be made of tapered self-cleaning teeth, approximately 1/8" high.
 2. Anti-Skid surface teeth shall have slots approximately 1/16" wide by 3/8" long, uniformly spaced with a minimum of 60 and a maximum of 80 teeth per square foot.

3. INSTALLATION

3.1 Site Examination

- A. Contractor shall examine the support structure, work area and conditions for the grating installation. If the supports, area or conditions are not satisfactory, installation shall not commence until satisfactory conditions are present.

3.2 Erection

- A. Grating shall be installed as detailed on the approved shop drawings.
- B. Grating shall be installed in single, unspliced sections for all requirements to 20' lengths.
- C. Grating shall interlock, with male-female legs providing a lock prohibiting horizontal movement. The outside leg of all members shall be male.
- D. Connections of grating to support elements shall be by bolting, clamping, screwing, welding or use of a manufacturers approved hold-down clip.