

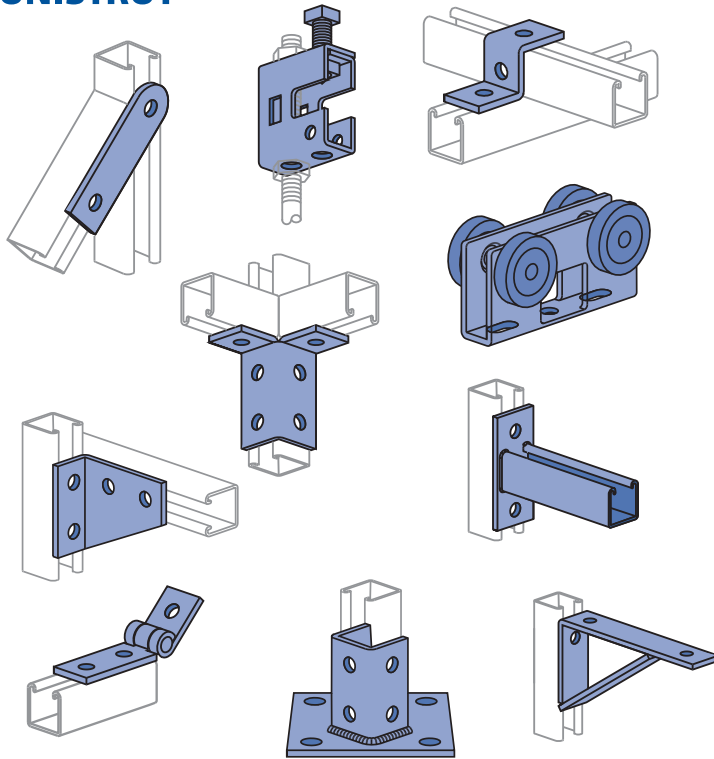

UNISTRUT

GENERAL FITTINGS



Flat Plate Fittings	75-76
Ninety Degree Fittings.....	76-79
Angular Fittings	79
"Z" Shape Fittings	80
"U" Shape Fittings	81-82
Wing Shape Fittings	82-84
Post Bases	84
Brackets	84-87
Brace Fittings.....	88
Beam Clamps.....	89-96
Trolleys.....	96
Special Application Fittings.....	97-98
Seismic Retrofit Fittings.....	98-100

MATERIAL

Fittings, unless noted, are made from hot-rolled, pickled and oiled steel plates, strip or coil, and conform to ASTM specifications A575, A576, A635, or A36. The fitting steel also meets the physical requirements of ASTM A1011 SS GR 33. The pickling of the steel produces a smooth surface free from scale.

Many fittings are also available in stainless steel, aluminum and fiberglass. Consult factory for ordering information.

FINISHES

Fittings are available in:

- Perma-Green III (GR),
- Electro-galvanized (EG), conforming to ASTM B633 Type III SC1;
- Hot-dipped galvanized (HG), conforming to ASTM A123 or A153 and
- Plain (PL).

APPLICATION

All parts drawings illustrate only one application of each fitting. In most cases many other applications are possible. The channels shown in the illustrations are P1000, 1 $\frac{1}{8}$ " square, except where noted otherwise.

All $\frac{9}{16}$ " diameter holes use $\frac{1}{2}$ " x $\frac{15}{16}$ " hex head cap screws and $\frac{1}{2}$ " nuts – P1010, P4010 or P5510 – depending on the channel used. Nuts and bolts are not included with the fitting and must be ordered separately.

DESIGN BOLT TORQUE

BOLT SIZE	¼"-20	⅝"-18	⅜"-16	½"-13	⅝"-11	¾"-10
Rec. Torque Ft/Lbs (N•m)	6 (8)	11 (15)	19 (26)	50 (68)	100 (136)	125 (170)
Max Torque Ft/Lbs (N•m)	7 (9)	15 (20)	25 (34)	70 (95)	125 (170)	135 (183)

SET SCREW TORQUE

BOLT SIZE	¼"-20	⅜"-16	½"-13	⅝"-11	¾"-10	⅞"-9
Set Screw Torque In/Lbs (N•m)	40 (4)	60 (7)	125 (14)	250 (28)	400 (44.5)	665 (75)

Note: Caution should be taken not to overtighten the set screw

DIMENSIONS

Imperial dimensions are illustrated in inches. Metric dimensions are shown in parenthesis or as noted. Unless noted, all metric dimensions are in millimeters and rounded to one decimal place.

DESIGN LOAD

Design load data, where shown, is based on the ultimate strength of the connection with a safety factor of 2.5, unless otherwise noted.

BEAM CLAMPS

Clamps are designed to be used with W, M, S and HP Shape beams, Standard C and Miscellaneous MC Channels, Angles and Structural Tees. Clamps must be used in pairs where indicated. For beam clamps with HG finish, standard hardware is EG finish. For optional stainless steel hardware, please contact the factory for availability.



1 1/2" Channel

Telestrut

Nuts & Hardware

General Fittings

Pipe/Conduit Supports

Electrical Fittings

Concrete Inserts

Unipier®

Flat Plate Fittings

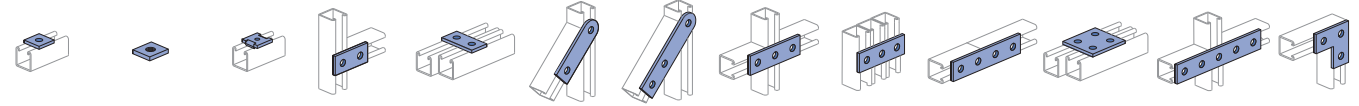

P1062-Pg 75 P1959-Pg 75 P2862-Pg 75 P1065-Pg 75 P1924-Pg 75 P2325-Pg 75 P2324-Pg 75 P1066-Pg 75 P1925-Pg 75 P1067-Pg 75 P2079-Pg 75 P1941-Pg 75 P1036-Pg 75

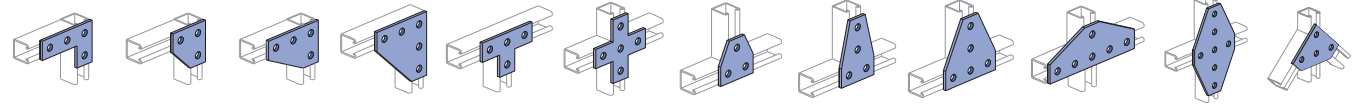

P1380 A-Pg 75 P1334-Pg 75 P1380-Pg 75 P1873-Pg 76 P1031-Pg 76 P1028-Pg 76 P1356-Pg 76 P1358-Pg 76 P1726-Pg 76 P1953-Pg 76 P1950-Pg 76 P1962-Pg 76

Angle Fittings

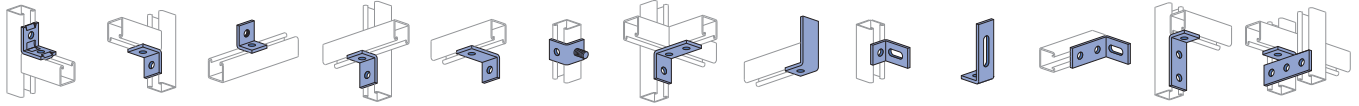

P2626-Pg 76 P1026-Pg 76 P1723-Pg 76 P1068-Pg 76 P1281-Pg 76 P1315-Pg 76 P1458-Pg 76 P1538A-Pg 77 P1750-Pg 77 P1498-Pg 77 P1747-Pg 77 P1326-Pg 77 P1821-Pg 77

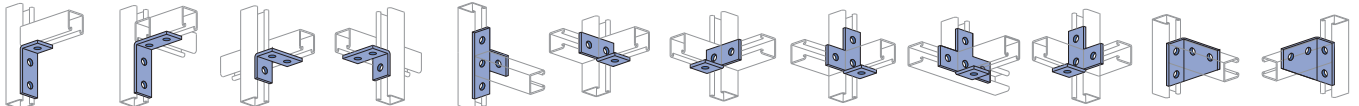

P1346-Pg 77 P1325-Pg 77 P1822-Pg 77 P1823-Pg 77 P1033-Pg 77 P1037-Pg 77 P1038-Pg 77 P1034-Pg 77 P1029-Pg 78 P1035-Pg 78 P1290-Pg 78 P1291-Pg 78

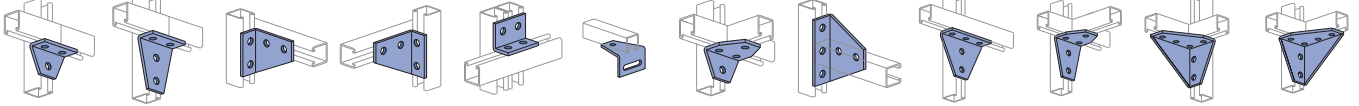

P1357-Pg 78 P1359-Pg 78 P1381-Pg 78 P1382-Pg 78 P1934-Pg 78 P1713-Pg 78 P1579-Pg 78 P1727-Pg 78 P1728-Pg 78 P2235-Pg 78 P1956-Pg 78 P1957-Pg 78

"Z" Shape Fittings

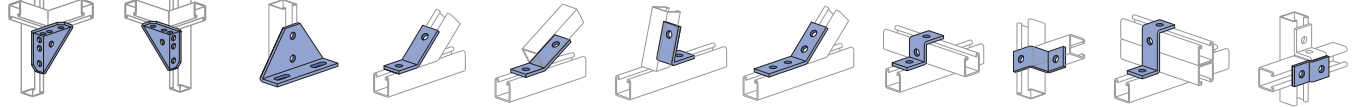

P2484-Pg 79 P2484W-Pg 79 P1130-Pg 79 P1546-Pg 79 P2101-Pg 79 P1186-Pg 79 P2260-Pg 79 P1045-Pg 80 P1347-Pg 80 P1453-Pg 80 P1454-Pg 80

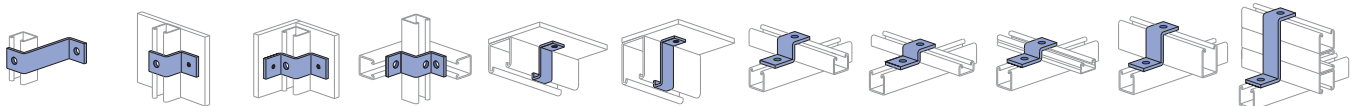

P1479A-Pg 80 P1730-Pg 80 P1734-Pg 80 P1736-Pg 80 P2360-Pg 80 P5560-Pg 80 P3045-Pg 80 P3345-Pg 80 P4045-Pg 80 P5545-Pg 80 P2469-Pg 80

"U" Shape Fittings

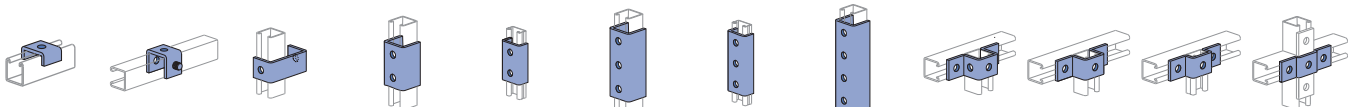

P2800-Pg 81 P1320-Pg 81 P1363A-Pg 81 P1376-Pg 81 P4376-Pg 81 P1376A-Pg 81 P4376A-Pg 81 P1377-Pg 81 P1047-Pg 81 P3047-Pg 81 P4047-Pg 81 P1455-Pg 81

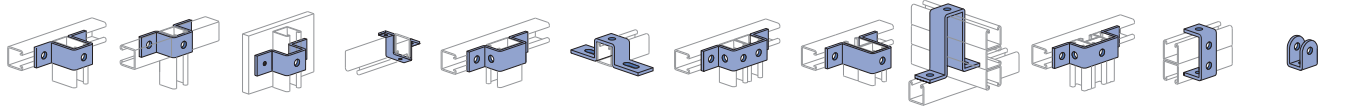

P5547-Pg 81 P1383-Pg 82 P1732-Pg 82 P2237-Pg 82 P5543-Pg 82 P1048-Pg 82 P1043A-Pg 82 P1737-Pg 82 P2473-Pg 82 P4043-Pg 82 P1044-Pg 82 P1973-Pg 82



P2326-Pg 82 P2328-Pg 82 P2329-Pg 82

Wing Shape Fittings

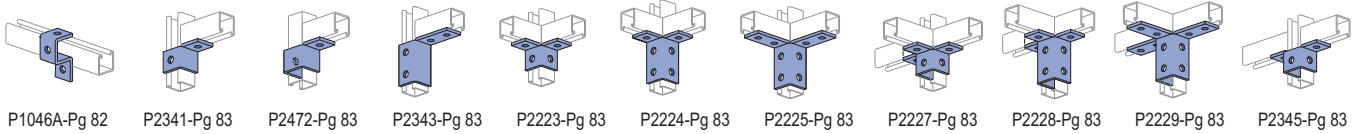

Post Bases



Brackets and Brace Fittings

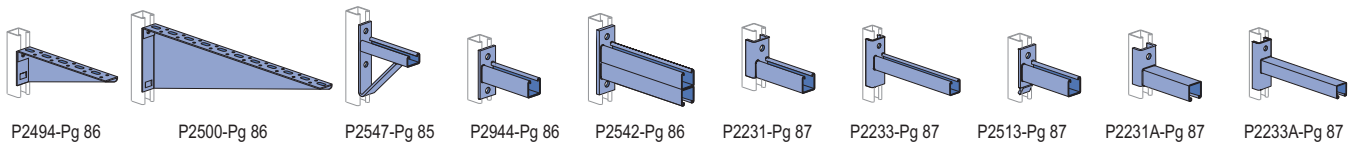
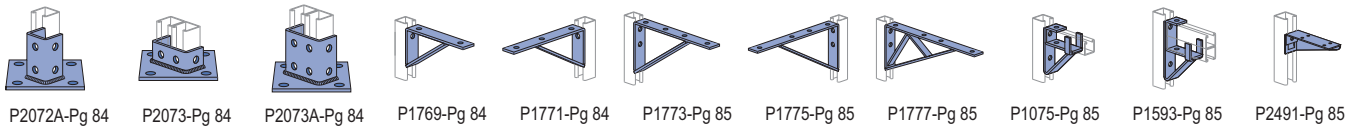

Beam Clamps

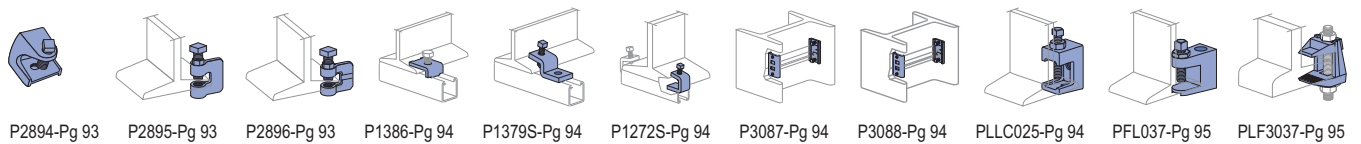
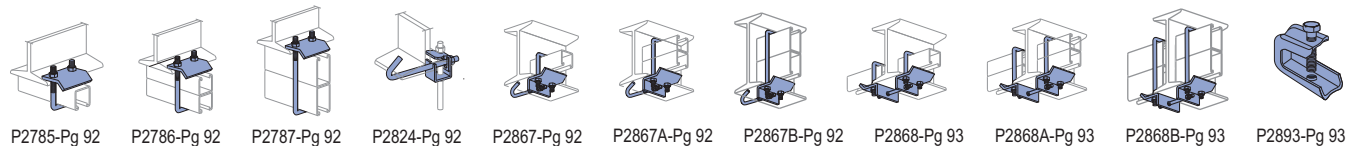
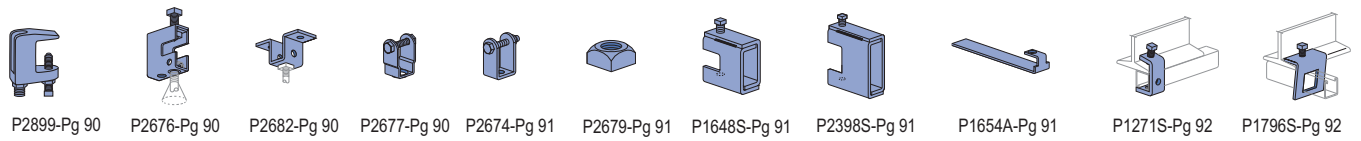
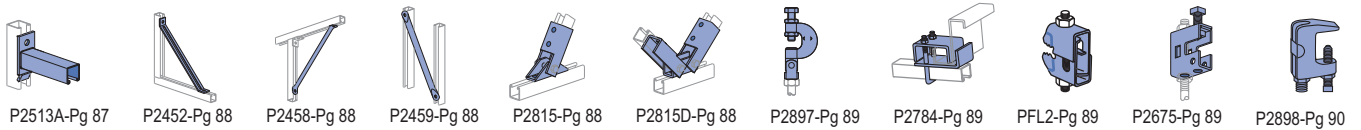

Trolley Assemblies

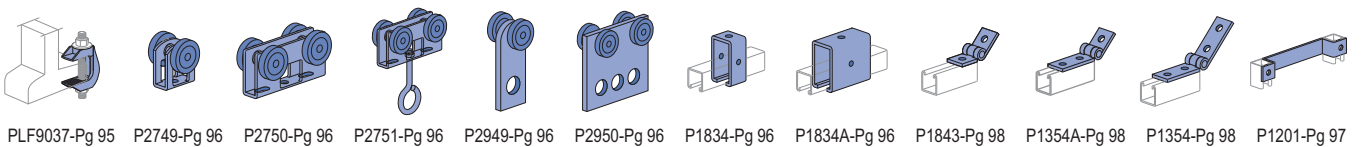

Special Applications Fittings

Seismic Retrofit Fittings

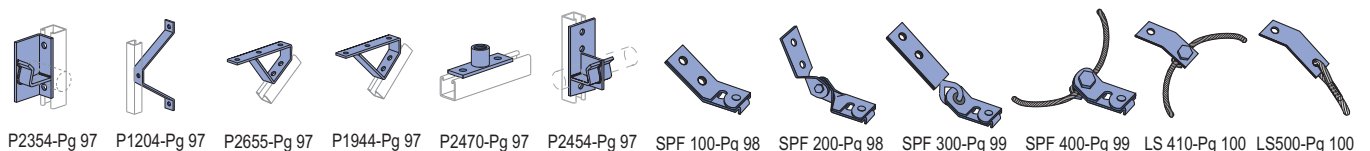



DESIGN LOAD DATA FOR TYPICAL UNISTRUT CHANNEL CONNECTIONS

90° Fittings (When used in position shown)

1 5/8" Channel

Telestrut

Nuts & Hardware

General Fittings

Pipe/Conduit Supports

Electrical Fittings

Concrete Inserts

Unipier®

		Channel Thickness		
Load – P1026		12 ga.	14 ga.	16 ga.
	Lbs	1,500	1,000	750
	kN	6.67	4.45	3.34

		Channel Thickness		
Load – P2484		12 ga.	14 ga.	16 ga.
	Lbs	3,000	2,000	1,500
	kN	13.34	8.90	6.67

		Channel Thickness		
Load – P1026		12 ga.	14 ga.	16 ga.
	Lbs	1,000	650	500
	kN	4.45	2.89	2.22

		Channel Thickness		
Load – P1068		12 ga.	14 ga.	16 ga.
	Lbs	500	500	500
	kN	2.22	2.22	2.22

		Channel Thickness		
Load – P1325, P2235		12 ga.	14 ga.	16 ga.
	Lbs	2,000	2,000	1,500
	kN	8.90	8.90	6.67

		Channel Thickness		
Load – P1326		12 ga.	14 ga.	16 ga.
	Lbs	500	500	500
	kN	2.22	2.22	2.22

		Channel Thickness		
Load – P1458, P1579		12 ga.	14 ga.	16 ga.
	Lbs	1,500	1,000	1,000
	kN	6.67	4.45	4.45

		Channel Thickness		
Load – P1346		12 ga.	14 ga.	16 ga.
	Lbs	1,200	1,200	1,000
	kN	5.34	5.34	4.45

		Channel Thickness		
Load – P1346		12 ga.	14 ga.	16 ga.
	Lbs	2,000	1,500	900
	kN	8.90	6.67	4.00

		Channel Thickness		
Load – P1065		12 ga.	14 ga.	16 ga.
	Lbs	1,000	800	600
	kN	4.45	3.56	2.67

- Note:
- (1) Both ends of beams supported.
 - (2) Load data is based on P1010 nut and 1/2" bolt.
 - (3) Safety factor = 2 1/2 based on ultimate strength of connection.

P1062, P1063, P1064, P1964, P2471, P2490

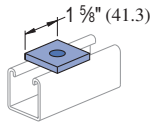

Part No.	Bolt Size	Hole Size	Wt/100 pcs Lbs (kg)
P1062	5/16"	1/2"	18 (8.2)
P1063	3/8"	7/16"	18 (8.2)
P1064	1/2"	9/16"	17 (7.7)
P1964	5/8"	1 1/16"	16 (7.3)
P2471	3/4"	1 3/16"	15 (6.8)
P2490	7/8"	1 5/16"	14 (6.4)

P1959, P1960, P1961

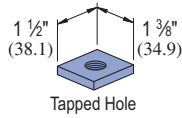

Part Number	U.S. Std. Thd Size	Wt/100 pcs Lbs (kg)
P1959	3/8" - 16	21 (9.5)
P1960	1/2" - 13	20 (9.1)
P1961	5/8" - 11	19 (8.6)

Material: 3/8" (9.5 mm) thick

P2862, 2863, 2864

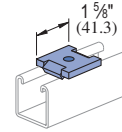

Part Number	Bolt Size	Hole Size	Wt/100 pcs Lbs (kg)
P2862	5/16"	1/2"	18 (8.2)
P2863	3/8"	7/16"	18 (8.2)
P2864	1/2"	9/16"	17 (7.7)

P1065

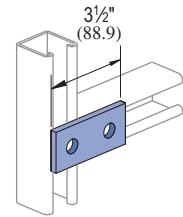

Wt/100 pcs: 38 Lbs (17.2 kg)

P1924

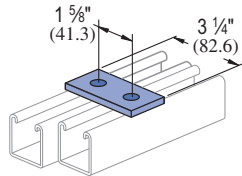

Wt/100 pcs: 35 Lbs (15.9 kg)

P2325

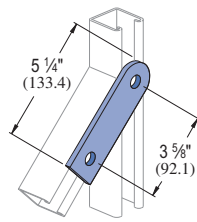

Wt/100 pcs: 55 Lbs (24.9 kg)

P2324

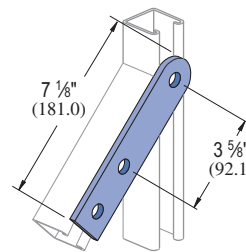

Wt/100 pcs: 75 Lbs (34.0 kg)

P1066

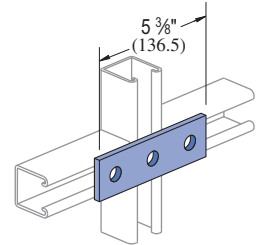

Wt/100 pcs: 56 Lbs (25.4 kg)

P1925

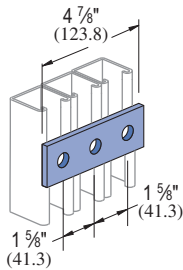

Wt/100 pcs: 50 Lbs (22.7 kg)

P1067

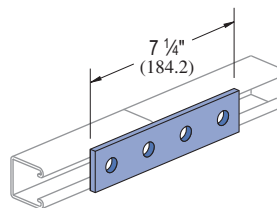

Wt/100 pcs: 78 Lbs (35.4 kg)

P2079

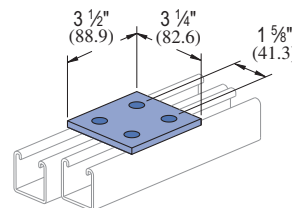

Wt/100 pcs: 73 Lbs (33.1 kg)

P1941

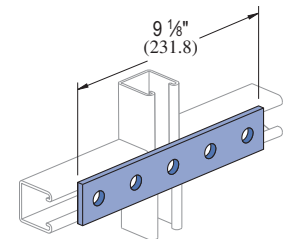

Wt/100 pcs: 94 Lbs (42.6 kg)

P1036

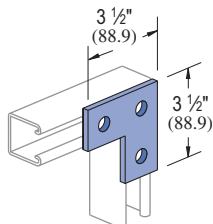

Wt/100 pcs: 58 Lbs (26.3 kg)

P1380 A

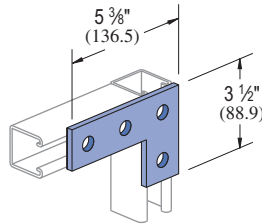

Wt/100 pcs: 80 Lbs (36.3 kg)

P1334

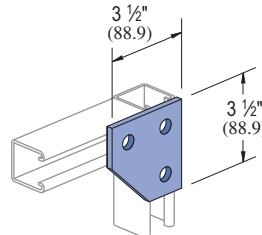

Wt/100 pcs: 70 Lbs (31.8 kg)

P1380

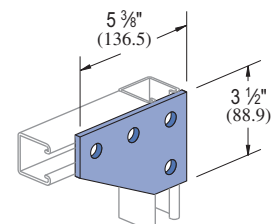

Wt/100 pcs: 105 Lbs (47.6 kg)

Standard Dimensions for 1 5/8" (41mm) width series channel fittings (Unless Otherwise Shown on Drawing)

Hole Diameter: 5/16" (14mm); Hole Spacing - From End: 1/8" (21mm); Hole Spacing - On Center: 1 1/8" (48mm); Width: 1 5/8" (41mm); Thickness: 1/4" (6mm)



1 5/8" Channel
Telestrut

Nuts & Hardware
General Fittings

Pipe/Conduit Supports
Electrical Fittings

Concrete Inserts
Unipier®

P1873

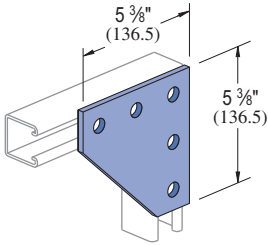

Wt/100 pcs: 150 Lbs (68.0 kg)

P1031

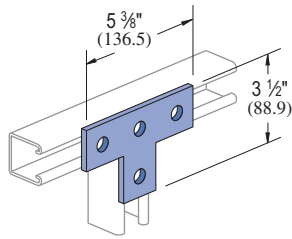

Wt/100 pcs: 80 Lbs (36.3 kg)

P1028

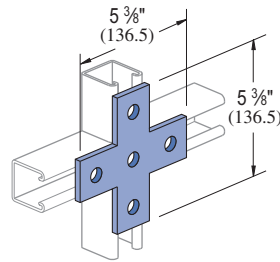

Wt/100 pcs: 105 Lbs (47.6 kg)

P1356

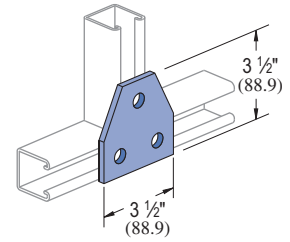

Wt/100 pcs: 70 Lbs (31.8 kg)

P1358

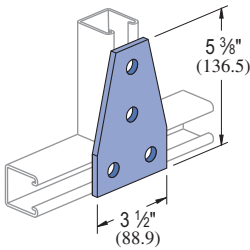

Wt/100 pcs: 105 Lbs (47.6 kg)

P1726

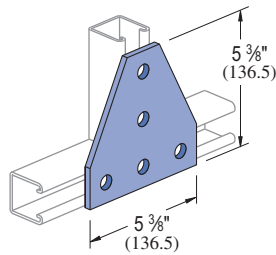

Wt/100 pcs: 148 Lbs (67.1 kg)

P1953

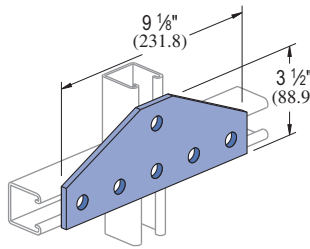

Wt/100 pcs: 176 Lbs (79.8 kg)

P1950

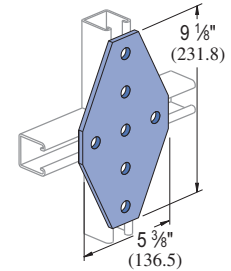

Wt/100 pcs: 240 Lbs (108.9 kg)

P1962

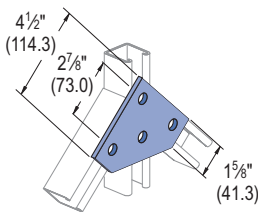

Wt/100 pcs: 112 Lbs (50.8 kg)

P2626

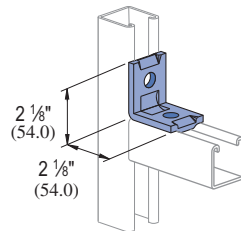

Wt/100 pcs: 40 Lbs (18.1 kg)

P1026

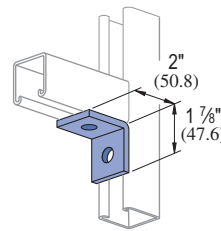

Wt/100 pcs: 38 Lbs (17.2 kg)

P1723

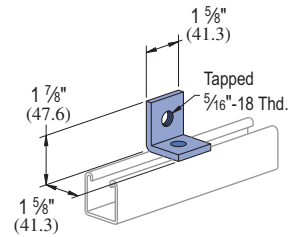

Wt/100 pcs: 34 Lbs (15.4 kg)

P1068

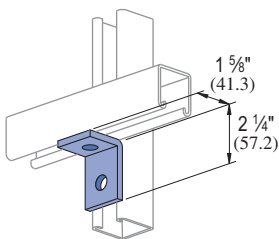

Wt/100 pcs: 38 Lbs (17.2 kg)

P1281, P1282, P1283

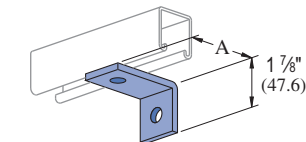

Part Number	"A" In (mm)	Wt/100 pcs Lbs (kg)
P1281	3	49
P1282	3 1/2	54
P1283	4	61

P1315

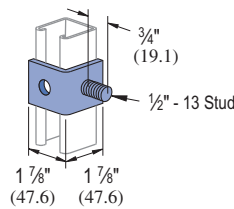

Wt/100 pcs: 45 Lbs (20.4 kg)

P1458

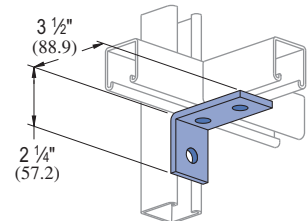

Wt/100 pcs: 58 Lbs (26.3 kg)

Standard Dimensions for 1 5/8" (41mm) width series channel fittings (Unless Otherwise Shown on Drawing)

Hole Diameter: 5/16" (14mm); Hole Spacing - From End: 1 1/16" (21mm); Hole Spacing - On Center: 1 7/8" (48mm); Width: 1 5/8" (41mm); Thickness: 1/4" (6mm)

P1538A THRU P1538D

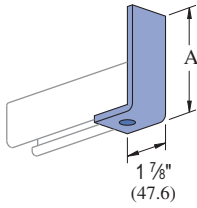

Part Number	"A" In (mm)	Wt/100 pcs Lbs (kg)
P1538A	3 7/8 98.4	61 27.7
P1538B	5 7/8 149.2	84 38.1
P1538C	7 7/8 200.0	107 48.5
P1538D	9 7/8 250.8	130 59.0

P1498, P1499

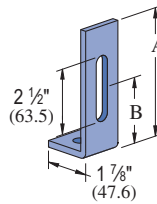

Part Number	"A" In (mm)	"B" In (mm)	Wt/100 pcs Lbs (kg)
P1498	4 7/8 123.8	2 1/2 63.5	65 29.5
P1499	6 7/8 174.6	4 1/2 114.3	85 38.6

P1750

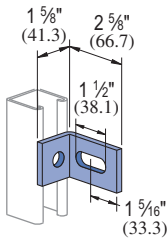

Wt/100 pcs: 38 Lbs (17.2 kg)

P1747

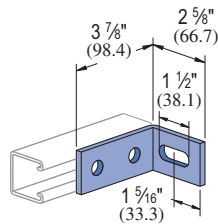

Wt/100 pcs: 66 Lbs (29.9 kg)

P1326

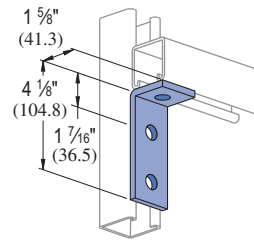

Wt/100 pcs: 58 Lbs (26.3 kg)

P1821

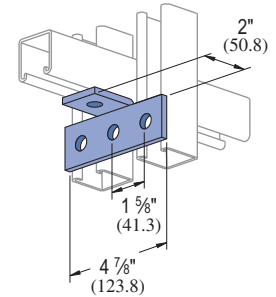

Wt/100 pcs: 71 Lbs (32.2 kg)

P1346

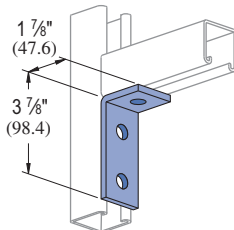

Wt/100 pcs: 58 Lbs (26.3 kg)

P1325

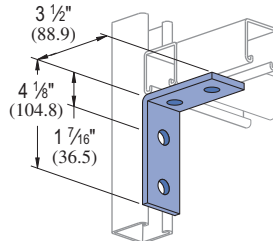

Wt/100 pcs: 78 Lbs (35.4 kg)

P1822

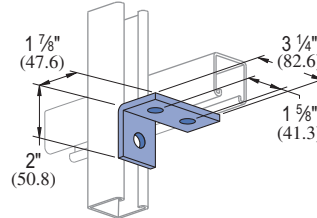

Wt/100 pcs: 55 Lbs (24.9 kg)

P1823

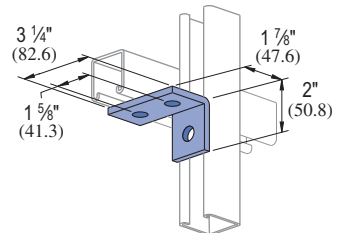

Wt/100 pcs: 55 Lbs (24.9 kg)

P1033

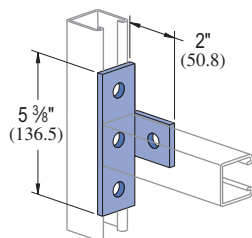

Wt/100 pcs: 80 Lbs (36.3 kg)

P1037

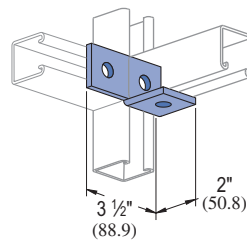

Wt/100 pcs: 58 Lbs (26.3 kg)

P1038

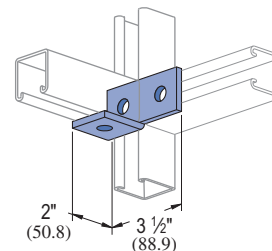

Wt/100 pcs: 58 Lbs (26.3 kg)

P1034

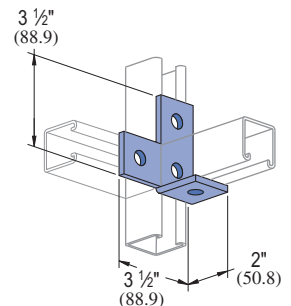

Wt/100 pcs: 80 Lbs (36.3 kg)

Standard Dimensions for 1 5/8" (41mm) width series channel fittings (Unless Otherwise Shown on Drawing)

Hole Diameter: 9/16" (14mm); Hole Spacing - From End: 1 1/8" (21mm); Hole Spacing - On Center: 1 7/8" (48mm); Width: 1 5/8" (41mm); Thickness: 1/4" (6mm)



P1029

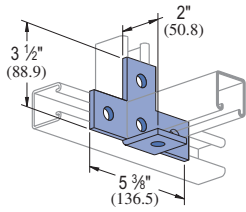

Wt/100 pcs: 105 Lbs (47.6 kg)

P1035

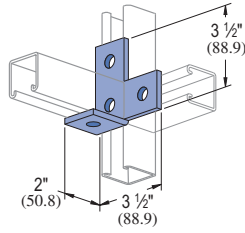

Wt/100 pcs: 80 Lbs (36.3 kg)

P1290

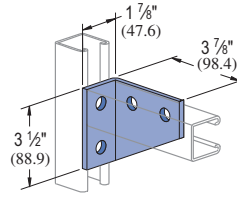

Wt/100 pcs: 101 Lbs (45.8 kg)

P1291

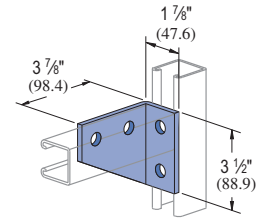

Wt/100 pcs: 101 Lbs (45.8 kg)

P1357

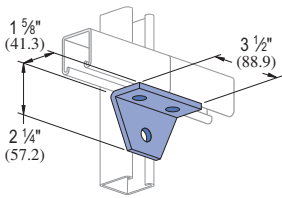

Wt/100 pcs: 70 Lbs (31.8 kg)

P1359

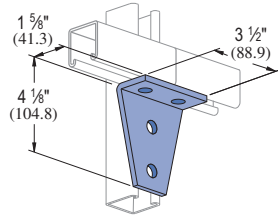

Wt/100 pcs: 105 Lbs (47.6 kg)

P1381

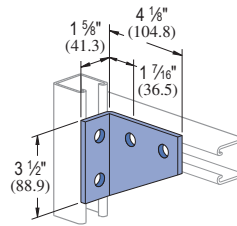

Wt/100 pcs: 105 Lbs (47.6 kg)

P1382

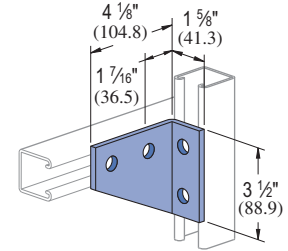

Wt/100 pcs: 105 Lbs (47.6 kg)

P1934

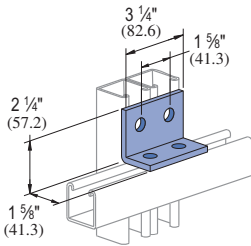

Wt/100 pcs: 75 Lbs (34.0 kg)

P1713

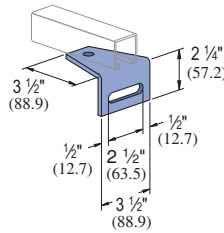

Wt/100 pcs: 97 Lbs (44.0 kg)

P1579

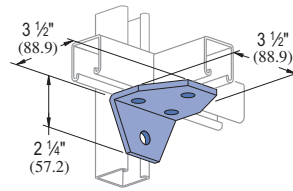

Wt/100 pcs: 103 Lbs (46.7 kg)

P1727

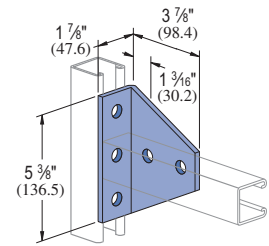

Wt/100 pcs: 154 Lbs (69.9 kg)

P1728

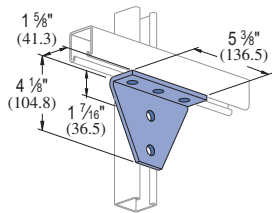

Wt/100 pcs: 154 Lbs (69.9 kg)

P2235

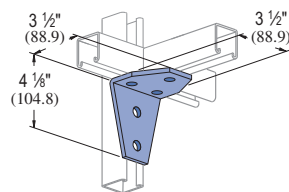

Wt/100 pcs: 135 Lbs (61.2 kg)

P1956

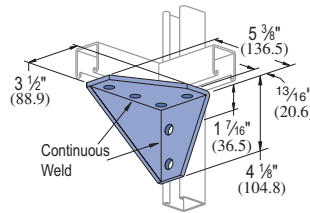

Wt/100 pcs: 230 Lbs (104.3 kg)

P1957

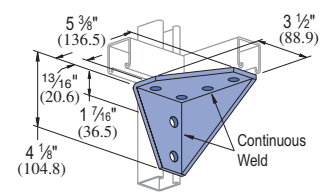

Wt/100 pcs: 230 Lbs (104.3 kg)

Standard Dimensions for 1 5/8" (41mm) width series channel fittings (Unless Otherwise Shown on Drawing)

Hole Diameter: 5/16" (14mm); Hole Spacing - From End: 1 3/16" (21mm); Hole Spacing - On Center: 1 7/8" (48mm); Width: 1 5/8" (41mm); Thickness: 1/4" (6mm)

P2484

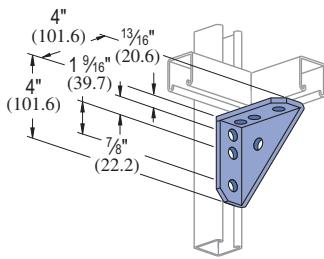

Wt/100 pcs: 134 Lbs (60.8 kg)

P2484W

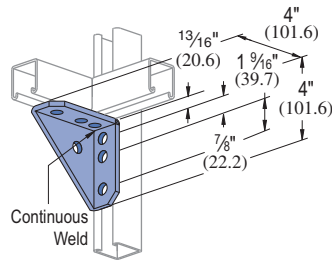

Wt/100 pcs: 134 Lbs (60.8 kg)

P1130, P1131

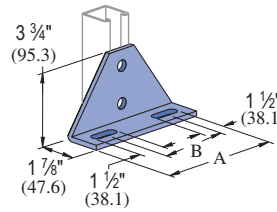

Part Number	"A" In (mm)	"B" In (mm)	Wt/100 pcs Lbs (kg)
P1130	6 ⁵ / ₁₆ 168.3	4 101.6	190 86.2
P1131	8 ⁵ / ₁₆ 219.1	6 152.4	242 109.8

P1546, P2094 THRU P2100

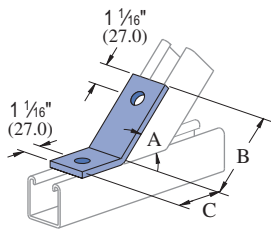

Part No.	"A" Degree (rad)	"B" In (mm)	"C" In (mm)
P2094	82½° 1.44	3 ³ / ₁₆ 90.5	1 ¹ / ₁₆ 42.9
P2095	75° 1.31	3 ³ / ₁₆ 90.5	1 ¹ / ₁₆ 42.9
P2096	67½° 1.18	3½ 88.9	1¾ 44.5
P2097	60° 1.05	3½ 85.7	1½ 47.6
P2098	52½° 0.92	3¼ 82.6	2 ¹ / ₁₆ 52.4
P1546	45° 0.79	3 76.2	2 ⁵ / ₁₆ 58.7
P2099	37½° 0.65	3½ 88.9	1 ¹³ / ₁₆ 46.0
P2100	37½° 0.65	2 ¹¹ / ₁₆ 68.3	2 ⁵ / ₁₆ 66.7

Wt/100 pcs: 58 Lbs (26.3 kg)

P2101 THRU P2104

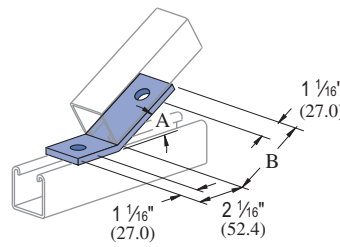

Part No.	"A" Degree (rad)	"B" In (mm)
P2101	30° 0.52	¾ 82.6
P2102	22½° 0.39	3 ³ / ₁₆ 84.1
P2103	15° 0.26	3 ³ / ₁₆ 84.1
P2104	7½° 0.13	3 ³ / ₁₆ 84.1

Wt/100 pcs: 58 Lbs (26.3 kg)

P1186, P2105 THRU P2110

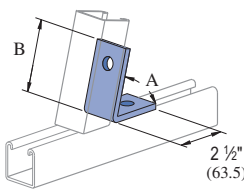

Part Number	"A" Degree (rad)	"B" In (mm)
P2105	82½° 1.44	3 ³ / ₁₆ 81.0
P2106	75° 1.31	3 ³ / ₁₆ 81.0
P2107	67½° 1.18	3½ 79.4
P2108	60° 1.05	3½ 79.4
P2109	52½° 0.92	3 ³ / ₁₆ 77.8
P1186	45° 0.79	3½ 79.4
P2110	37½° 0.65	3 76.2

Wt/100 pcs: 58 Lbs (26.3 kg)

P2260 THRU P2270

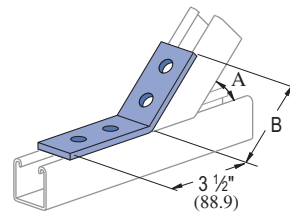

Part Number	"A" Degree (rad)	"B" In (mm)
P2270	82½° 1.44	3½ 92.1
P2269	75° 1.31	3½ 92.1
P2268	67½° 1.18	3½ 92.1
P2267	60° 1.05	3 ¹¹ / ₁₆ 93.7
P2266	52½° 0.92	3 ¹¹ / ₁₆ 93.7
P2265	45° 0.79	3 ¹¹ / ₁₆ 93.7
P2264	37½° 0.65	3 ¹¹ / ₁₆ 93.7
P2263	30° 0.52	3 ¹¹ / ₁₆ 93.7
P2262	22½° 0.39	3¾ 95.3
P2261	15° 0.26	3¾ 95.3
P2260	7½° 0.13	3¾ 95.3

Wt/100 pcs: 78 Lbs (35.4 kg)

Standard Dimensions for 1½" (41mm) width series channel fittings (Unless Otherwise Shown on Drawing)

Hole Diameter: 9/16" (14mm); Hole Spacing - From End: 1/16" (21mm); Hole Spacing - On Center: 1½" (48mm); Width: 1½" (41mm); Thickness: ¼" (6mm)



P1045

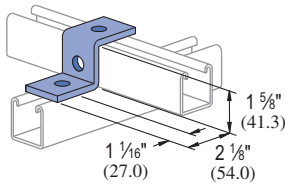

Wt/100 pcs: 55 Lbs (24.9 kg)

P1347

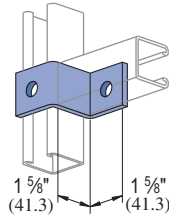

Wt/100 pcs: 55 Lbs (24.9 kg)

P1453

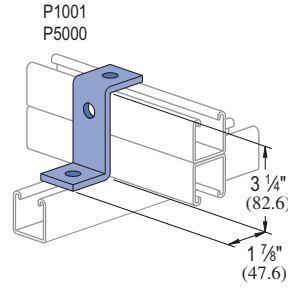

Wt/100 pcs: 70 Lbs (31.8 kg)

P1454

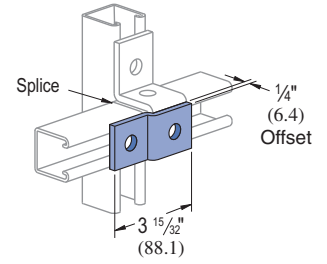

Wt/100 pcs: 38 Lbs (17.2 kg)

P1479A THRU P1479E

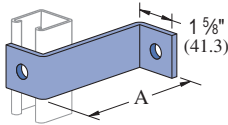

Part Number	"A" In (mm)	Wt/100 pcs Lbs (kg)
P1479A	4	81
P1479B	5	92
P1479C	6	104
P1479D	7	115
P1479E	8	127
	203.2	57.6

P1730

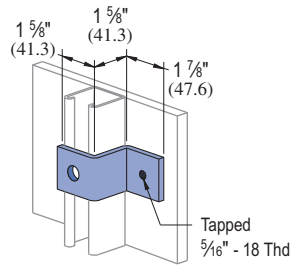

Wt/100 pcs: 54 Lbs (24.5 kg)

P1734

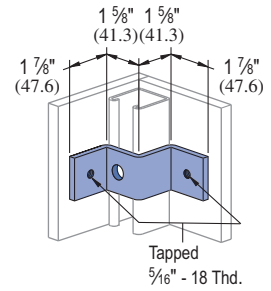

Wt/100 pcs: 70 Lbs (31.8 kg)

P1736

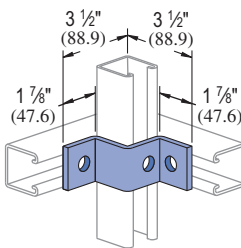

Wt/100 pcs: 70 Lbs (31.8 Kg)

P2360

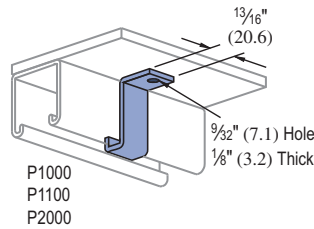

Wt/100 pcs: 9 Lbs (4.1 kg)

P5560

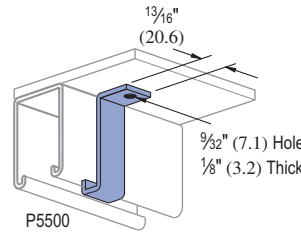

Wt/100 pcs: 11 Lbs (5.0 kg)

P3045

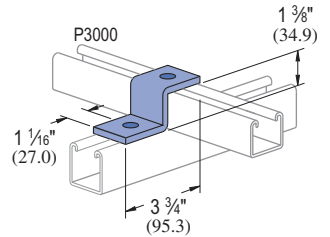

Wt/100 pcs: 53 Lbs (24.0 kg)

P3345

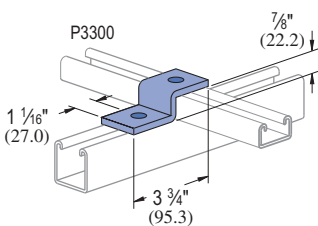

Wt/100 pcs: 47 Lbs (21.3 kg)

P4045

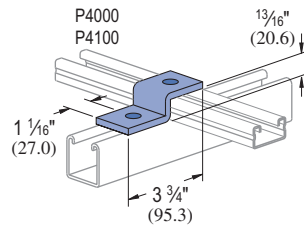

Wt/100 pcs: 47 Lbs (21.3 kg)

P5545

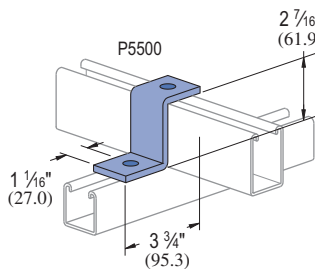

Wt/100 pcs: 67 Lbs (30.4 kg)

P2469

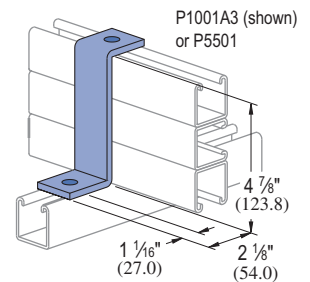

Wt/100 pcs: 93 Lbs (42.2 kg)

Standard Dimensions for 1 5/8" (41mm) width series channel fittings (Unless Otherwise Shown on Drawing)

Hole Diameter: 9/16" (14mm); Hole Spacing - From End: 1 3/16" (21mm); Hole Spacing - On Center: 1 7/8" (48mm); Width: 1 5/8" (41mm); Thickness: 1/4" (6mm)

P2800

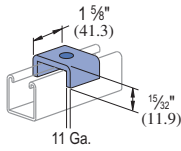

Part Number	Bolt Size In	Wt/100 pcs Lbs (kg)
P2800-25	1/4"	14 6.4
P2800-37	3/8"	14 6.4
P2800-50	1/2"	13 5.9
P2800-62	5/8"	13 5.9
P2800-75	3/4"	13 5.9

P1363A THRU P1363E

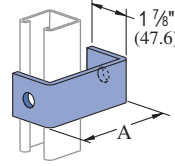

Part Number	"A" In (mm)	Wt/100 pcs Lbs (kg)
P1363A	4 101.6	78 35.4
P1363B	5 127.0	89 40.4
P1363C	6 152.4	101 45.8
P1363D	7 177.8	112 50.8
P1363E	8 203.2	124 56.2

P1320

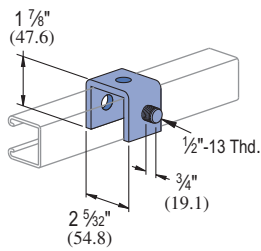

Wt/100 pcs: 63 Lbs (28.6 kg)

P1376

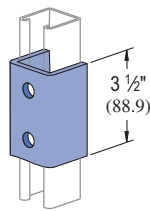

Wt/100 pcs: 128 Lbs (58.1 kg)

P4376

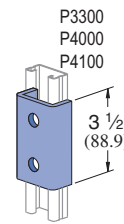

Wt/100 pcs: 85 Lbs (38.6 kg)

P1376A

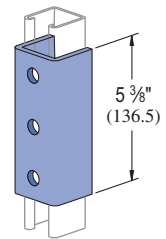

Wt/100 pcs: 197 Lbs (89.4 kg)

P4376A

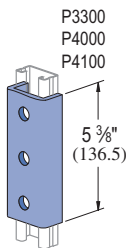

Wt/100 pcs: 130 Lbs (59.0 kg)

P1377, P4377, P5077, P5577

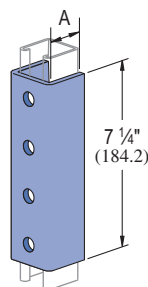

Part Number	For Use With	Wt/100 pcs Lbs (kg)
P1377	P1000, P1100, P2000	265 120
P4377	P3300, P4000, P4100	176 80
P5077	P5000	390 177
P5577	P5500	310 141

P1047

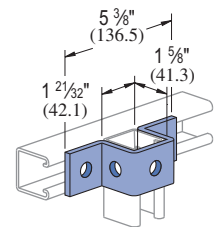

Wt/100 pcs: 88 Lbs (39.9 kg)

P3047

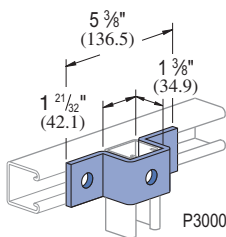

Wt/100 pcs: 84 Lbs (38.1 kg)

P4047

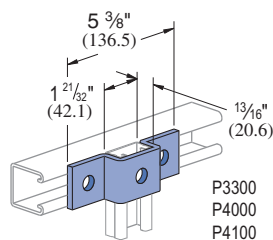

Wt/100 pcs: 71 Lbs (32.2 kg)

P1455

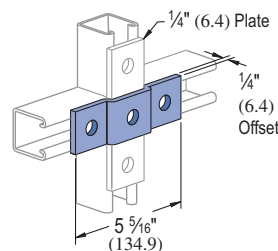

Wt/100 pcs: 58 Lbs (26.3 kg)

P5547

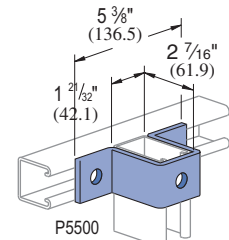

Wt/100 pcs: 108 Lbs (49.0 kg)

Standard Dimensions for 1 5/8" (41mm) width series channel fittings (Unless Otherwise Shown on Drawing)

Hole Diameter: 9/16" (14mm); Hole Spacing - From End: 1 1/8" (21mm); Hole Spacing - On Center: 1 1/2" (48mm); Width: 1 5/8" (41mm); Thickness: 1/4" (6mm)



P1383

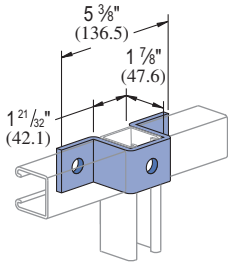

Wt/100 pcs: 95 Lbs (43.1 kg)

P1732

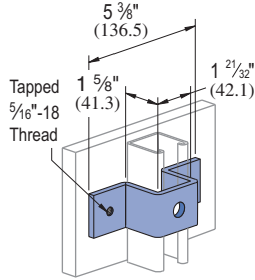

Wt/100 pcs: 88 Lbs (39.9 kg)

P2237

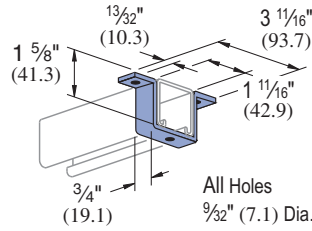

Material: 1/8" (3.2) thick.

Wt/100 pcs: 18 Lbs (8.2 kg)

P5543

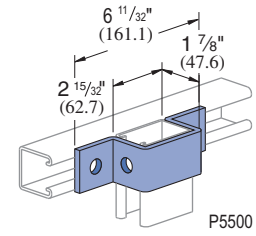

Wt/100 pcs: 97 Lbs (44.0 kg)

P1048, P1049, P1050

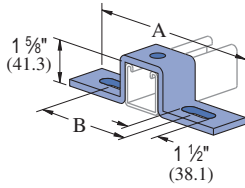

Part Number	"A" In (mm)	"B" In (mm)	Wt/100 pcs Lbs (kg)
P1048	7 1/4 184.2	4 1/8 104.8	105 47.6
P1049	8 1/2 215.9	5 1/8 136.5	120 54.4
P1050	10 3/8 263.5	7 1/4 184.2	130 59.0

P1043A

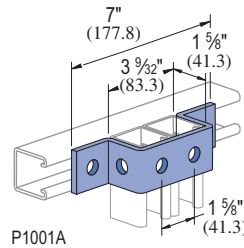

P1001A

Wt/100 pcs: 105 Lbs (47.6 kg)

P1737

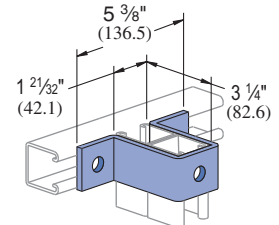

P1001(shown), P1101, P2001, P4004 or P5000

Wt/100 pcs: 128 Lbs (58.1 kg)

P2473

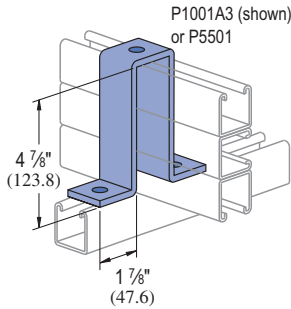

Wt/100 pcs: 197 Lbs (89.4 kg)

P4043

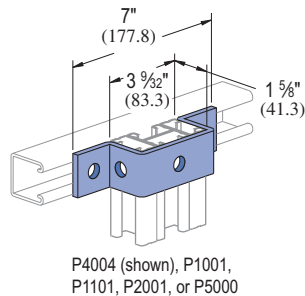

P4004 (shown), P1001, P1101, P2001, or P5000

Wt/100 pcs: 106 Lbs (48.1 kg)

P1044

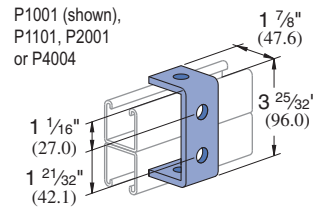

P1001 (shown), P1101, P2001 or P4004

Wt/100 pcs: 70 Lbs (31.8 kg)

P1973

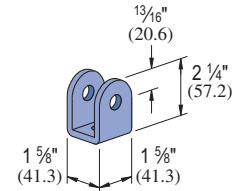

Wt/100 pcs: 53 Lbs (24.0 kg)

P2326

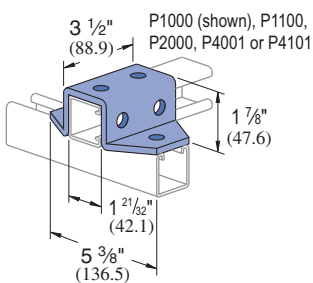

Wt/100 pcs: 171 Lbs (77.6 kg)

P2328

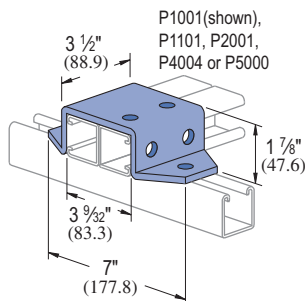

Wt/100 pcs: 209 Lbs (94.8 kg)

P2329

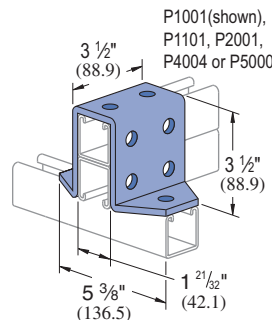

Wt/100 pcs: 257 Lbs (116.6 kg)

P1046A

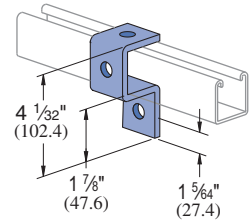

Wt/100 pcs: 76 Lbs (34.5 kg)

Standard Dimensions for 1 5/8" (41mm) width series channel fittings (Unless Otherwise Shown on Drawing)

Hole Diameter: 9/16" (14mm); Hole Spacing - From End: 13/16" (21mm); Hole Spacing - On Center: 1 7/8" (48mm); Width: 1 5/8" (41mm); Thickness: 1/4" (6mm)

P2341 R-L

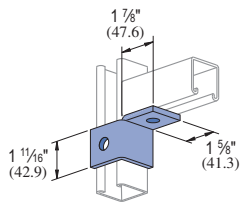

R - As shown
L - Opposite hand

Wt/100 pcs: 60 Lbs (27.2 kg)

P2224

P2472 R-L

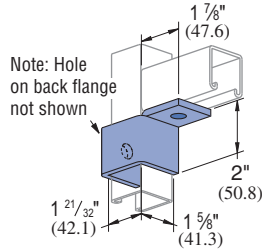

R - As shown
L - Opposite hand

Wt/100 pcs: 75 Lbs (34.0 kg)

P2225

P2343 R-L

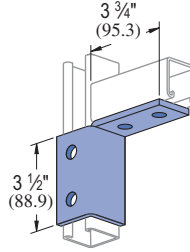

R - As shown
L - Opposite hand

Wt/100 pcs: 119 Lbs (54.0 kg)

P2227

P2223

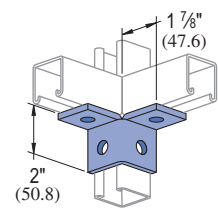

Wt/100 pcs: 76 Lbs (34.5 kg)

P2228

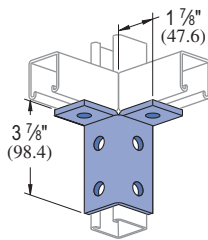

Wt/100 pcs: 115 Lbs (52.2 kg)

P2229

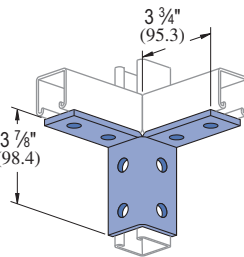

Wt/100 pcs: 155 Lbs (70.3 kg)

P2345

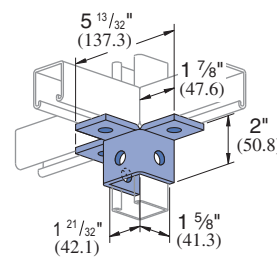

Wt/100 pcs: 113 Lbs (51.3 kg)

P2346

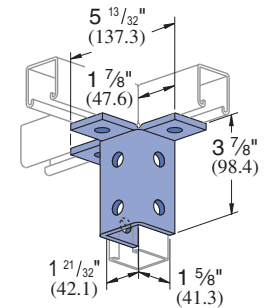

Wt/100 pcs: 177 Lbs (80.3 kg)

P2347

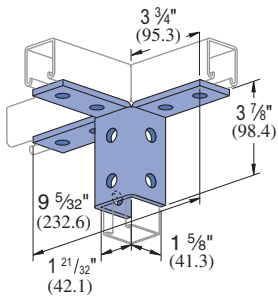

Wt/100 pcs: 230 Lbs (104.3 kg)

P2344 R-L

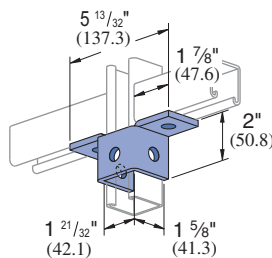

Wt/100 pcs: 93 Lbs (42.2 kg)

P2226

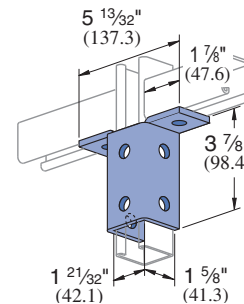

Wt/100 pcs: 150 Lbs (68.0 kg)

P2230

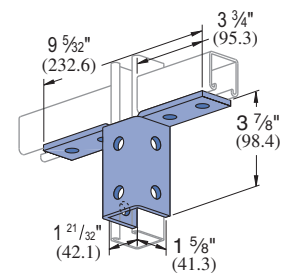

Wt/100 pcs: 193 Lbs (87.5 kg)

P2245

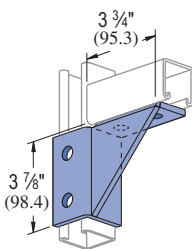

R - As shown
L - Opposite hand

Wt/100 pcs: 176 Lbs (79.8 kg)

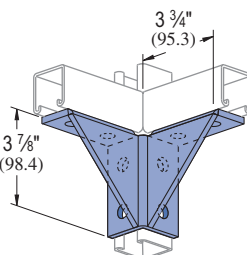

Wt/100 pcs: 217 Lbs (98.4 kg)

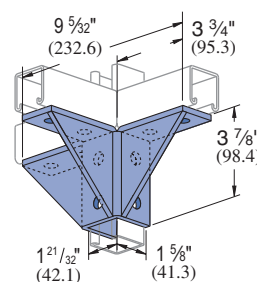

Wt/100 pcs: 310 Lbs (140.6 kg)

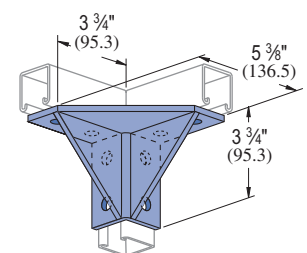

Wt/100 pcs: 315 Lbs (142.9 kg)

Standard Dimensions for 1 1/2" (41mm) width series channel fittings (Unless Otherwise Shown on Drawing)

Hole Diameter: 9/16" (14mm); Hole Spacing - From End: 1/16" (21mm); Hole Spacing - On Center: 1 1/8" (48mm); Width: 1 1/2" (41mm); Thickness: 1/4" (6mm)



P2348

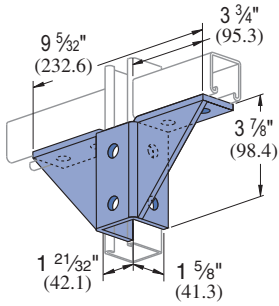

Wt/100 pcs: 274 Lbs (124.3 kg)

P2453

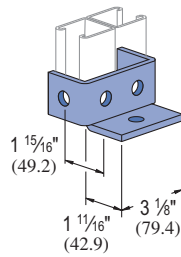

Wt/100 pcs: 116 Lbs (52.6 kg)

P1887

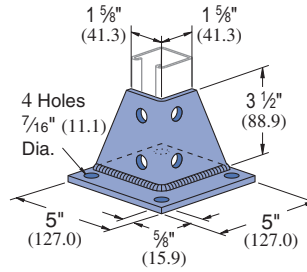

Wt/100 pcs: 297 Lbs (134.8 kg)

P2941, P2942

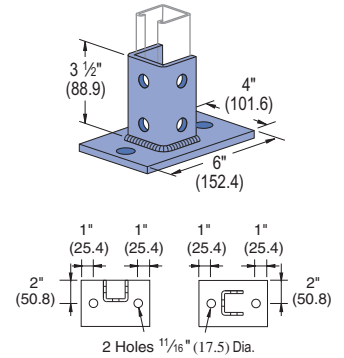

P2941

P2942

Wt/100 pcs: 358 Lbs (162.4 kg)

P2072, P2072 SQ

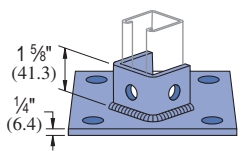

P2072

P2072A, P2072A SQ

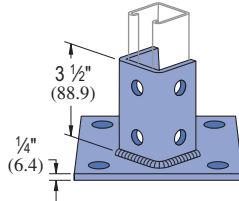

P2072A

P2073, P2073 SQ

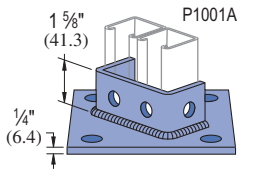

P2073

P2073A, P2073A SQ

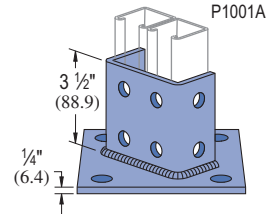

P2073A

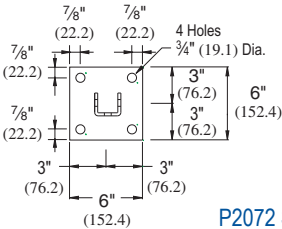
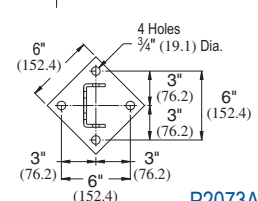
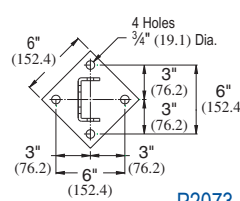
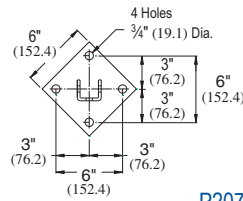
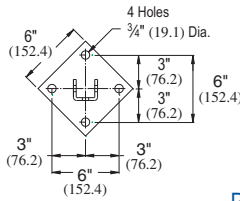

P2072 SQ

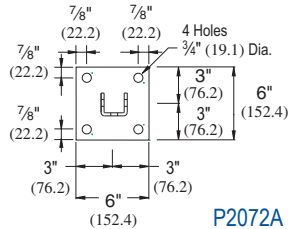

P2072A SQ

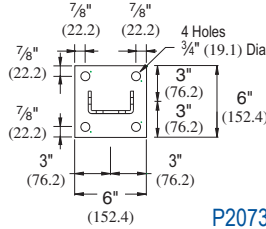

P2073 SQ

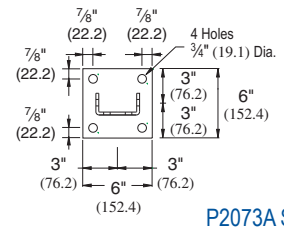

P2073A SQ

Wt/100 pcs: 307 Lbs (139.3 kg)

Wt/100 pcs: 373 Lbs (169.2 kg)

Wt/100 pcs: 325 Lbs (147.4 kg)

Wt/100 pcs: 408 Lbs (185.1 kg)

P1769

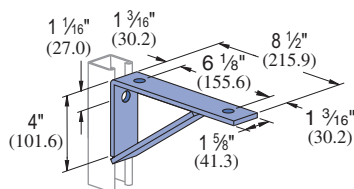

Material: 1/4" (6.4) thick steel.

Wt/100 pcs: 174 Lbs (78.9 kg)

Part No.	Vertical Channel Gauge	Uniform Design Load	
		Lbs	(kN)
P1000	12	800	3.56
P1100	14	600	2.67
P2000	16	400	1.81

Safety Factor 2 1/2

P1771

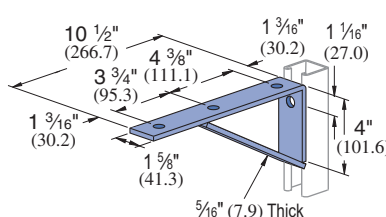

Material: 1/4" (6.4) thick steel.

Wt/100 pcs: 206 Lbs (93.4 kg)

Part No.	Vertical Channel Gauge	Uniform Design Load	
		Lbs	(kN)
P1000	12	800	3.56
P1100	14	600	2.67
P2000	16	400	1.81

Safety Factor 2 1/2

Standard Dimensions for 1 1/2" (41mm) width series channel fittings (Unless Otherwise Shown on Drawing)

Hole Diameter: 5/16" (14mm); Hole Spacing - From End: 1/16" (21mm); Hole Spacing - On Center: 1 1/8" (48mm); Width: 1 1/2" (41mm); Thickness: 1/4" (6mm)

Note : When used for mechanical supports, load capacities of brackets and fittings should be in compliance with the American Standard Code for Pressure Piping.

P1773

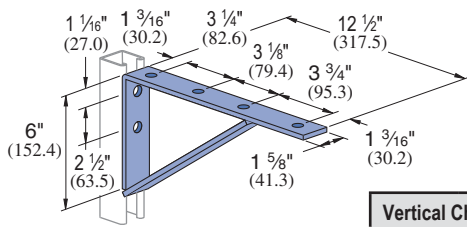

Material: 1/4" (6.4) thick steel.

Part No.	Gauge	Vertical Channel	Uniform Design Load Lbs (kN)
P1000	12	12	900 (4.00)
P1100	14	14	800 (3.56)
P2000	16	16	450 (2.04)

Safety Factor 2 1/2

Wt/100 pcs: 264 Lbs (119.7 kg)

P1775

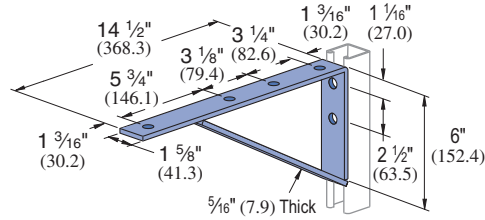

Material: 1/4" (6.4) thick steel.

Part No.	Gauge	Vertical Channel	Uniform Design Load Lbs (kN)
P1000	12	12	900 (4.00)
P1100	14	14	800 (3.56)
P2000	16	16	450 (2.04)

Safety Factor 2 1/2

Wt/100 pcs: 295 Lbs (133.8 kg)

P1075

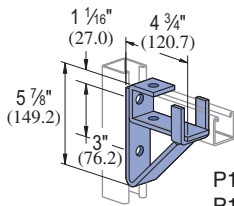

P1000
P1100
P2000
P4001

Material: 1/4" (6.4) thick steel.

Wt/100 pcs: 229 Lbs (103.9 kg)

Part No.	Gauge	Vertical Channel	Allowable Moment* In-Lbs (N•M)
P1000	12	12	5,100 (576)
P1100	14	14	4,400 (497)
P2000	16	16	3,200 (362)

Safety Factor 2 1/2

* Allowable moment for fitting only. Channel may determine overall capacity.

P1593

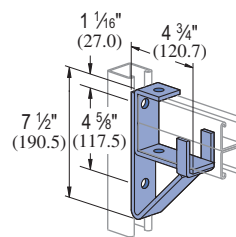

P1001
P1101
P5000
P2001

Material: 1/4" (6.4) thick steel.

Wt/100 pcs: 272 Lbs (123.4 kg)

Part No.	Gauge	Vertical Channel	Allowable Moment* In-Lbs (N•M)
P1000	12	12	13,000 1,469
P1100	14	14	9,100 1,028
P2000	16	16	6,500 734

Safety Factor 2 1/2

* Allowable moment for fitting only. Channel may determine overall capacity.

P1777

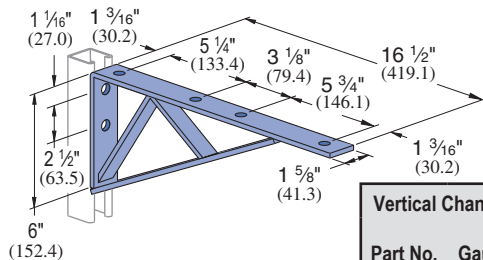

Material: 1/4" (6.4) thick steel.

Wt/100 pcs: 385 Lbs (174.6 kg)

Part No.	Gauge	Vertical Channel	Uniform Design Load Lbs (kN)
P1000	12	12	1,200 (5.44)
P1100	14	14	900 (4.00)
P2000	16	16	600 (2.67)

Safety Factor 2 1/2

P2547 THRU P2551

CABLE TRAY BRACKET

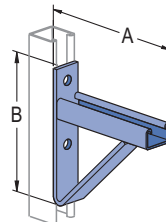

Part Number	"A" In (mm)	"B" In (mm)	Wt/100 pcs Lbs (kg)	Uniform Load* Lbs (kN)
P2547	15	8 3/4	420	1,000
	381.0	222	190.5	4.45
P2548	21	8 3/4	628	1,000
	533.4	222	284.9	4.45
P2549	27	11 1/4	860	900
	685.8	286	390.1	4.00
P2550	33	11 1/4	1010	900
	838.2	286	458.1	4.00
P2551	39	16	1257	800
	990.6	406.4	683.3	3.56

P2491 R-L THRU P2493 R-L

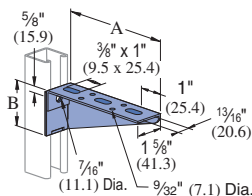

R - As shown; L - Opposite hand

Material : 12 Gauge Steel.

Part No.	Gauge	Vertical Channel	Uniform Design Load Lbs (kN)
P1000	12	12	300 (1.33)
P1100	14	14	250 (1.11)
P2000	16	16	200 (.89)

Safety Factor - 2 1/2

Part Number	Stamped Ident. No.	"A" In (mm)	"B" In (mm)	Wt/100 pcs Lbs (kg)
P2491 R-L	121892 R-L	6	1 1/16	67
		152.4	49.2	30.4
P2492 R-L	121893 R-L	8	2 7/16	92
		203.2	61.9	41.7
P2493 R-L	121894 R-L	10	2 5/16	120
		254.0	74.6	54.4

Standard Dimensions for 1 1/8" (41mm) width series channel fittings (Unless Otherwise Shown on Drawing)

Hole Diameter: 3/16" (14mm); Hole Spacing - From End: 1 3/16" (21mm); Hole Spacing - On Center: 1 1/8" (48mm); Width: 1 1/8" (41mm); Thickness: 1/4" (6mm)

Note : When used for mechanical supports, load capacities of brackets and fittings should be in compliance with the American Standard Code for Pressure Piping.



P2494 R-L THRU P2499 R-L

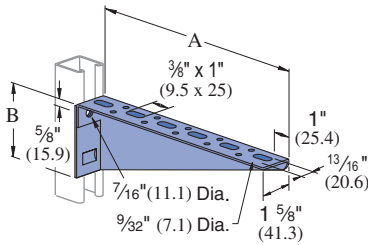

Vertical Channel Part No.	Gauge	Uniform Design Load Lbs (kN)
P1000	12	300 (1.33)
P1100	14	250 (1.11)
P2000	16	200 (.89)

Safety Factor - 2½

Part Number	Stamped Ident. No.	"A" In (mm)	"B" In (mm)	Wt/100 pcs Lbs (kg)
P2494 R-L	121895 R-L	12 304.8	3 7/16 87.3	152 68.9
P2495 R-L	121896 R-L	14 355.6	3 15/16 100.0	173 78.5
P2496 R-L	121897 R-L	16 406.4	4 1/16 112.7	223 101.2
P2497 R-L	121898 R-L	18 457.2	4 15/16 125.4	266 120.7
P2498 R-L	121899 R-L	20 508.0	5 1/16 138.1	308 139.7
P2499 R-L	121900 R-L	22 558.8	5 15/16 150.8	355 161.0

Material : 12 Gauge Steel.
R - As shown; L - Opposite hand

P2500 R-L THRU P2503 R-L

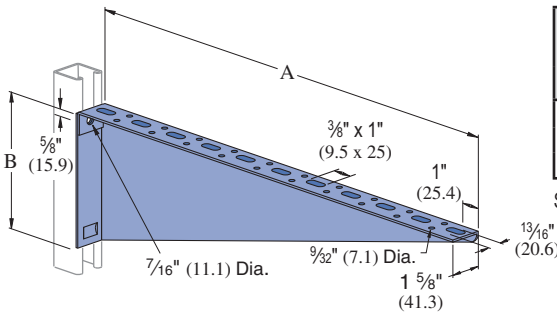

Vertical Channel Part No.	Gauge	Uniform Design Load Lbs (kN)
P1000	12	300 (1.33)
P1100	14	250 (1.11)
P2000	16	200 (.89)

Safety Factor - 2½

Part Number	Stamped Ident. No.	"A" In (mm)	"B" In (mm)	Wt/100 pcs Lbs (kg)
P2500 R-L	121901 R-L	24 609.6	6 1/16 164	400 181.4
P2501 R-L	121902 R-L	26 660	6 15/16 176	445 201.8
P2502 R-L	121903 R-L	28 711	7 1/16 189	493 223.6
P2503 R-L	121904 R-L	30 762.0	7 15/16 202	545 247.2

Material : 12 Gauge Steel.
R - As shown; L - Opposite hand

P2944, P2945, P2946, P2947

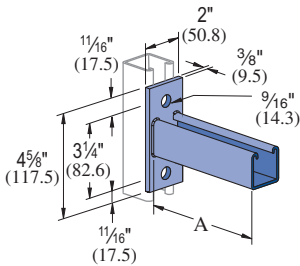

Part Number	"A" In (mm)	Wt/100 pcs Lbs (kg)	Uniform Load* Lbs (kN)
P2944	6 152.4	185 84	1200 5.34
P2945	12 304.8	293 133	600 2.67
P2946	18 457.2	401 182	400 1.78
P2947	24 609.6	509 231	300 1.33

Safety Factor 2½
* Mounted on 12 Ga. Channel

P2542 THRU P2546

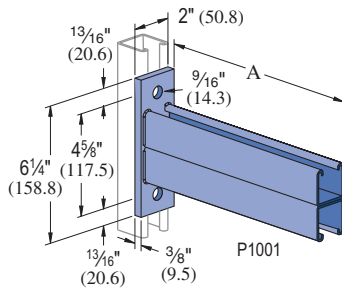

Safety Factor - 2½

Part Number	"A" In (mm)	Wt/100 pcs Lbs (kg)	Vertical Channel Part No.	Gauge	Uniform Design Load Lbs (kN)
P2542	12 304.8	502 228	P1000	12	2,000 (8.90)
			P1100	14	1,400 (6.23)
			P2000	16	1,000 (4.45)
P2543	18 457.2	692 314	P1000	12	1,300 (5.78)
			P1100	14	900 (4.00)
			P2000	16	650 (2.89)
P2544	24 609.6	882 400	P1000	12	1,000 (4.45)
			P1100	14	700 (3.11)
			P2000	16	500 (2.22)
P2545	30 762.0	1,072 486	P1000	12	800 (3.56)
			P1100	14	560 (2.49)
			P2000	16	400 (1.78)
P2546	36 914.4	1,262 572	P1000	12	650 (2.89)
			P1100	14	450 (2.00)
			P2000	16	320 (1.42)

Standard Dimensions for 1 5/8" (41mm) width series channel fittings (Unless Otherwise Shown on Drawing)

Hole Diameter: 5/16" (14mm); Hole Spacing - From End: 1/16" (21mm); Hole Spacing - On Center: 1 7/8" (48mm); Width: 1 5/8" (41mm); Thickness: 1/4" (6mm)

Note : When used for mechanical supports, load capacities of brackets and fittings should be in compliance with the American Standard Code for Pressure Piping.

P2231, P2232

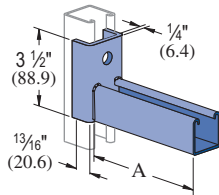

Part Number	"A" In (mm)	Wt/100 pcs Lbs (kg)	Vertical Channel Part No.	Gauge	Uniform Design Load Lbs (kN)
P2231	6	191	P1000	12	1,600 (7.12)
	152.4	86.6	P1100	14	1,200 (5.34)
			P2000	16	800 (3.56)
P2232	12	292	P1000	12	800 (3.56)
	304.8	132.4	P1100	14	600 (2.67)
			P2000	16	400 (1.78)

Safety Factor - 2½

P2231A, P2232A

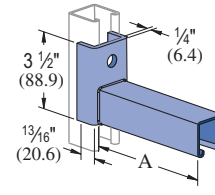

Part Number	"A" In (mm)	Wt/100 pcs Lbs (kg)	Vertical Channel Part No.	Gauge	Uniform Design Load Lbs (kN)
P2231A	6	191	P1000	12	1,600 (7.12)
	152.4	86.6	P1100	14	1,200 (5.34)
			P2000	16	800 (3.56)
P2232A	12	292	P1000	12	800 (3.56)
	304.8	132.4	P1100	14	600 (2.67)
			P2000	16	400 (1.78)

Safety Factor - 2½

P2233, P2234

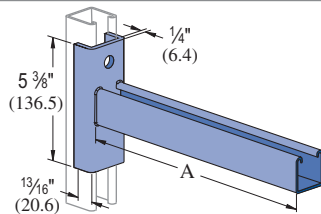

Part Number	"A" In (mm)	Wt/100 pcs Lbs (kg)	Vertical Channel Part No.	Gauge	Uniform Design Load Lbs (kN)
P2233	18	436	P1000	12	600 (2.67)
	457.2	197.8	P1100	14	450 (2.00)
			P2000	16	300 (1.33)
P2234	24	536	P1000	12	450 (2.00)
	609.6	243.1	P1100	14	330 (1.47)
			P2000	16	220 (.98)

Safety Factor - 2½

P2233A, P2234A

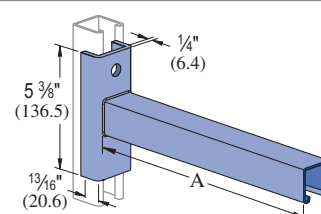

Part Number	"A" In (mm)	Wt/100 pcs Lbs (kg)	Vertical Channel Part No.	Gauge	Uniform Design Load Lbs (kN)
P2233A	18	436	P1000	12	600 (2.67)
	457.2	197.8	P1100	14	450 (2.00)
			P2000	16	300 (1.33)
P2234A	24	536	P1000	12	450 (2.00)
	609.6	243.1	P1100	14	330 (1.47)
			P2000	16	220 (.98)

Safety Factor - 2½

P2513 THRU P2516

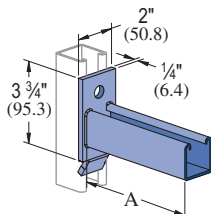

When installed in inverted position use 60% of loads shown.

Safety Factor 2½

Part Number	"A" In (mm)	Wt/100 pcs Lbs (kg)	Vertical Channel Part No.	Gauge	Uniform Design Load Lbs (kN)
P2513	6	161	P1000	12	1,200 (5.34)
	152.4	73.0	P1100	14	800 (3.56)
			P2000	16	600 (2.67)
P2514	12	261	P1000	12	600 (2.67)
	304.8	118.4	P1100	14	400 (1.78)
			P2000	16	300 (1.33)
P2515	18	361	P1000	12	400 (1.78)
	457.2	163.7	P1100	14	270 (1.20)
			P2000	16	200 (.89)
P2516	24	461	P1000	12	300 (1.33)
	609.6	209.1	P1100	14	200 (.89)
			P2000	16	150 (.67)

P2513A THRU P2516A

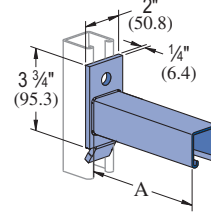

When installed in inverted position use 60% of loads shown.

Safety Factor 2½

Part Number	"A" In (mm)	Wt/100 pcs Lbs (kg)	Vertical Channel Part No.	Gauge	Uniform Design Load Lbs (kN)
P2513A	6	161	P1000	12	1,200 (5.34)
	152.4	73.0	P1100	14	800 (3.56)
			P2000	16	600 (2.67)
P2514A	12	261	P1000	12	600 (2.67)
	304.8	118.4	P1100	14	400 (1.78)
			P2000	16	300 (1.33)
P2515A	18	361	P1000	12	400 (1.78)
	457.2	163.7	P1100	14	270 (1.20)
			P2000	16	200 (.89)
P2516A	24	461	P1000	12	300 (1.33)
	609.6	209.1	P1100	14	200 (.89)
			P2000	16	150 (.67)

Standard Dimensions for 1½" (41mm) width series channel fittings (Unless Otherwise Shown on Drawing)

Hole Diameter: 5/16" (14mm); Hole Spacing - From End: 13/16" (21mm); Hole Spacing - On Center: 1½" (48mm); Width: 1½" (41mm); Thickness: 1/4" (6mm)

Note : When used for mechanical supports, load capacities of brackets and fittings should be in compliance with the American Standard Code for Pressure Piping.



1 5/8" Channel
Telestrut

Nuts & Hardware

General Fittings

Pipe/Conduit Supports

Electrical Fittings

Concrete Inserts

P2815

ADJUSTABLE BRACE FITTING

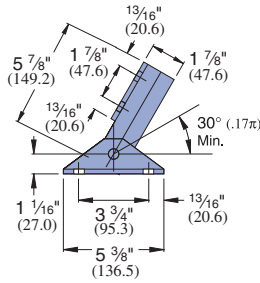
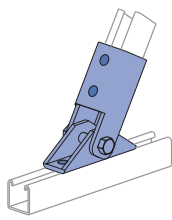

Wt/100 pcs: 307 Lbs (139.3 kg)

P2815D

ADJUSTABLE BRACE FITTING

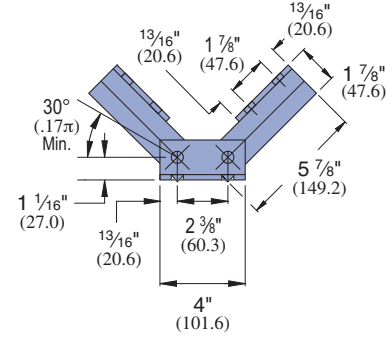
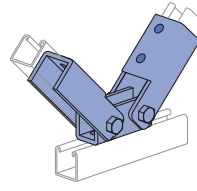

Wt/100 pcs: 497 Lbs (225.4 kg)

P2452

KNEE BRACE

P2458-18 THRU P2458-36

TUBULAR KNEE BRACES

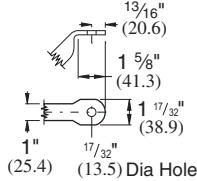
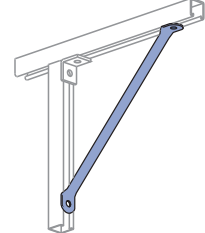
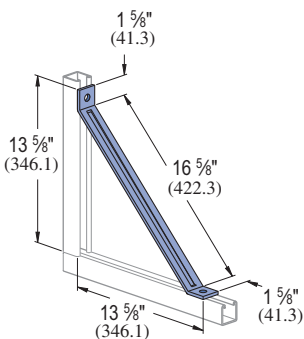

Design Axial Load
1200 Lbs (5.34 kN)

Material: 1/4" (6.4) thick steel.

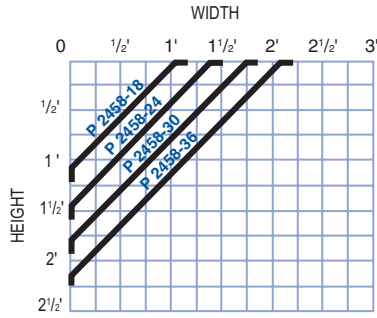
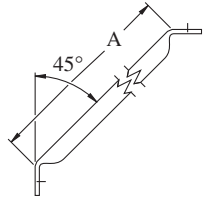

Part Number	"A" In (mm)	Wt/100 pcs Lbs (kg)
P2458-18	18	146
	457.2	66.2
P2458-24	24	186
	609.6	84.4
P2458-30	30	227
	762.0	103.0
P2458-36	36	267
	914.4	121.1

Design Loads
Compression = 1500 Lbs (6.67 kN)
Tension = 300 Lbs (1.33 kN)

Wt/100 pcs: 277 Lbs (125.6 kg)

P2459-36 THRU P2459-96

TUBULAR BACK BRACES

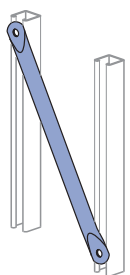

- The vertical lines of the graph correspond to the center to center line dimension of the uprights.
- Along this vertical line locate the (maximum usable) horizontal bracing height line.
- The arc line that intersects the point formed by the intersection of the two lines, indicates the brace required.
- 60° - 30° maximum, minimum brace angles are indicated for maximum effect.

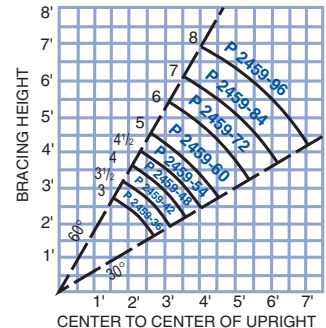
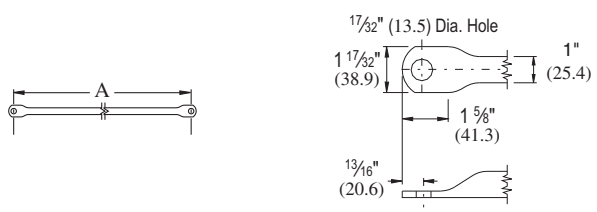

Part Number	"A" In (mm)	Wt/100 pcs Lbs (kg)
P2459-36	36	255
	914.4	115.7
P2459-42	42	296
	1,066.8	134.3
P2459-48	48	336
	1,219.2	152.4
P2459-54	54	377
	1,371.6	171.0
P2459-60	60	418
	1,524.0	189.6
P2459-66	66	459
	1,676.4	208.2
P2459-72	72	499
	1,828.8	226.3
P2459-78	78	540
	1,981.2	244.4
P2459-84	84	580
	2,133.6	263.1
P2459-90	90	621
	2,286.0	281.2
P2459-96	96	661
	2,438.4	299.8

Standard Dimensions for 1 5/8" (41mm) width series channel fittings (Unless Otherwise Shown on Drawing)

Hole Diameter: 5/16" (14mm); Hole Spacing - From End: 1/16" (21mm); Hole Spacing - On Center: 1 1/8" (48mm); Width: 1 5/8" (41mm); Thickness: 1/4" (6mm)

Note: When used for mechanical supports, load capacities of brackets and fittings should be in compliance with the American Standard Code for Pressure Piping.

P2897

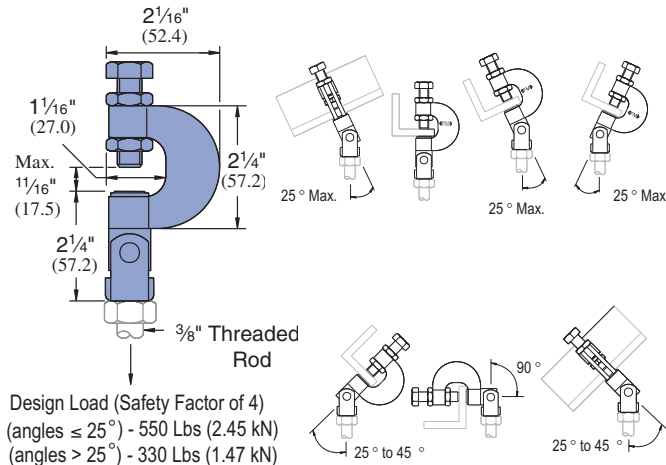

Design Load (Safety Factor of 4)
 (angles $\leq 25^\circ$) - 550 Lbs (2.45 kN)
 (angles $> 25^\circ$) - 330 Lbs (1.47 kN)

Safety Factor 4
 Torque: 13 Ft-Lbs (18 N*m)

Wt/100 pcs: 33 Lbs (15.0 kg)

P2784

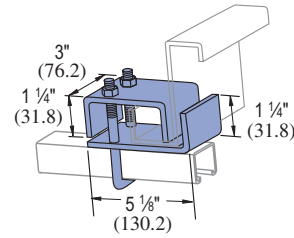

Part Number	For Use With	Load Lbs (kN)	Wt/100 pcs Lbs (kg)
P2784-1	P1000, P1100, P2000	1,200	175
		5.34	79.3
P2784-2	P1001, P1101, P2001	1,200	179
		5.34	81.1
P2784-3	P5001, P5501	1,200	180
		5.34	81.5

PFL2-37

SWIFTGRIP

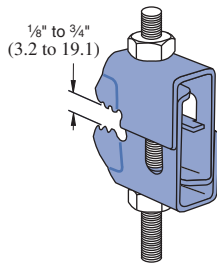

Designed to significantly reduce installation time, while offering greater performance than cast beam clamps, the Swiftgrip enables connection of drop rod to beam in one simple operation. Ideal for the suspension of building services equipment including heating, ventilating and air conditioning equipment; pipework; fire protection systems; electrical equipment and cable tray.

Available finish choices are Stainless Steel or Perma-Gold™ Industry Standard Yellow Dichromate.
 Design Load is 540 Lbs (2.40 kN).
 Safety Factor is 4
 Torque is 8 Ft/Lbs (10.8 N*m)
 Rod Size is $\frac{3}{8}"$ (9.5mm)

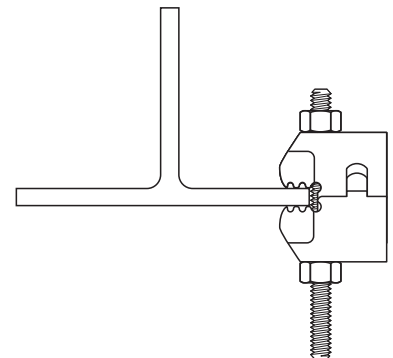

Wt/100 pcs: 26 Lbs (11.9 kg)

P2675

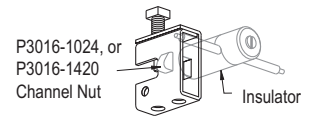
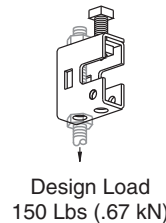
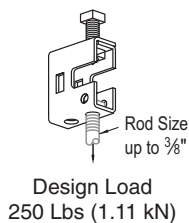
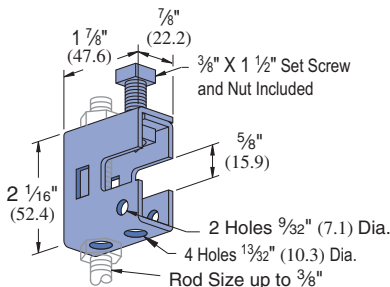

Clamp Materials: .105" (2.7) thick steel.
 Clamp P2675 is designed for light duty rod suspension.
 It also may be used with P3016-1024 or P3016-1420 nut as illustrated above for mounting insulators, etc.

Wt/100 pcs: 33 Lbs (15.0 kg)

Standard Dimensions for 1 1/8" (41mm) width series channel fittings (Unless Otherwise Shown on Drawing)

Hole Diameter: 9/16" (14mm); Hole Spacing - From End: 1 1/16" (21mm); Hole Spacing - On Center: 1 7/8" (48mm); Width: 1 1/8" (41mm); Thickness: 1/4" (6mm)

Note: When used for mechanical supports, load capacities of brackets and fittings should be in compliance with the American Standard Code for Pressure Piping. Clamps are designed to be used with W, M, S & HP Shape beams, Standard C & Misc. MC Channels, Angles & Structural Tees. Clamps must be used in pairs where indicated. For beam clamps with HG finish, standard hardware is EG finish. For optional stainless steel hardware, please contact the factory for availability.



1 5/8" Channel

Telestrut

Nuts & Hardware

General Fittings

Pipe/Conduit Supports

Electrical Fittings

Concrete Inserts

P2676

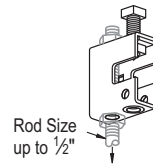
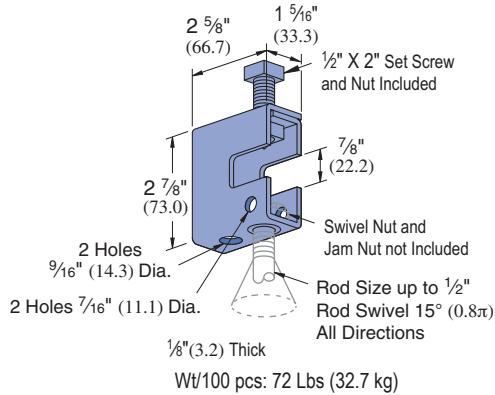

Design Load
300 Lbs (1.33 kN)



Design Load
500 Lbs (2.22 kN)

Clamp P2676 provides a means of rod suspension where a free swing of up to 15° (0.8π) is required. Clamp will accommodate 1/4" (6.4), 3/8" (9.5), or 1/2" (12.7) rods. Order swivel nuts P2679-4, -6, or -8 as required. Clamp may also be used with P2677 as illustrated in application drawings.
Clamp Materials: 1/8" (3.2) thick steel.

P2898

UNIVERSAL BEAM CLAMP

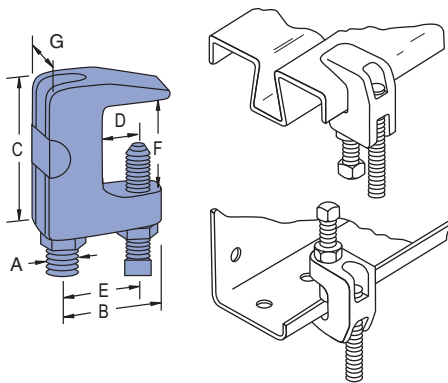

- Maximum temperature of 450° F (232° C)
- At least one full thread must be exposed

	A In	B In (mm)	C In (mm)	D In (mm)	E In (mm)	F In (mm)	G In (mm)	Max Load Lbs (kN)	Wt/100 pcs Lbs (kg)
P2898-37	3/8	1	1 1/2	1/2	1	3/4	7/8	400 1.78	33 15.0
P2898-50	1/2	1	1 1/2	1/2	1	3/4	7/8	500 2.22	33 15.0
P2898-62	5/8	1 1/2	1 1/2	1/2	1	3/4	1	600 2.67	22 10.0
P2898-75	3/4	1 7/8	1 3/4	5/8	1 1/8	1	1 1/4	800 3.56	88 40.0
P2898-87	7/8	2	1 3/4	5/8	1 1/2	1	1 1/4	1,200 5.34	79 35.9

P2899

WIDE THROAT BEAM CLAMP

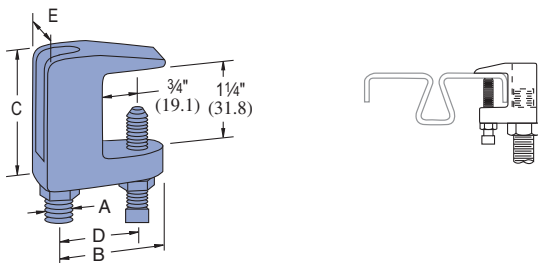

- Maximum temperature of 450° F (232° C)

	Rod Size					Max. Load Lbs (kN)	Wt/100 pcs Lbs (kg)
	A in	B In (mm)	C In (mm)	D In (mm)	E In (mm)		
P2899-37	3/8	1 5/8	2	1	7/8	400 1.78	28 12.7
P2899-50	1/2	1 5/8	2	1	7/8	500 2.22	34 15.4
P2899-62	5/8	1 3/4	2 1/4	1 1/4	1	600 2.67	66 30.0
P2899-75	3/4	1 7/8	2 3/8	1 3/8	1 1/4	800 3.56	83 37.7

P2682

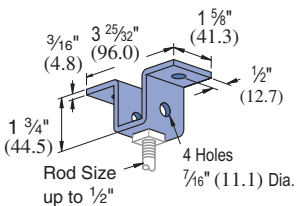

Hanger clevis for up to 1/2" (12.7) rod suspension from wood ceilings. May also be used with P2677 as illustrated in application drawings.

Wt/100 pcs: 55 Lbs (24.9 kg)

P2677

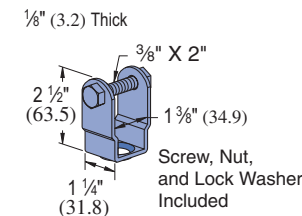
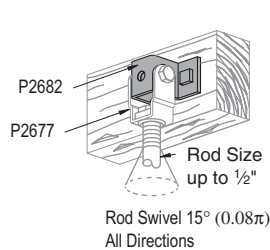

Clevis hanger to be used with P2676 or P2682 to provide angle adjustment and 15° (0.08 π) free swing for up to 1/2" (12.7) rod suspension. Order swivel nuts P2679-4, -6, or -8 as required.

Wt/100 pcs: 30 Lbs (13.6 kg)

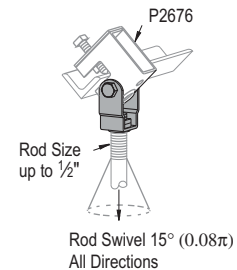

Design Load
500 Lbs (2.22 kN)

Note: When used for mechanical supports, load capacities of brackets and fittings should be in compliance with the American Standard Code for Pressure Piping. Clamps are designed to be used with W, M, S & HP Shape beams, Standard C & Misc. MC Channels, Angles & Structural Tees. Clamps must be used in pairs where indicated. For beam clamps with HG finish, standard hardware is EG finish. For optional stainless steel hardware, please contact the factory for availability.

P2674

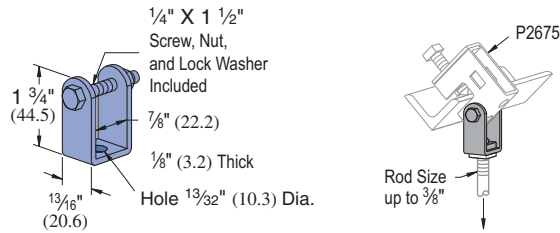

Clevis hanger to be used with P2675 to provide angle adjustment for up to 3/8\"/>

Wt/100 pcs: 17 Lbs (7.7 kg)

Design Load
250 Lbs (1.11 kN)

P2679-4, -6 & -8

SWIVEL NUT

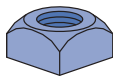

Part Number	Thread Size	Wt/100 pcs Lbs (kg)
P2679-4	1/4"-20	4 1.8
P2679-6	3/8"-16	5 2.3
P2679-8	1/2"-13	6 2.7

- Use with P2676 and P2677.
- Order size as required.

P2398S, P2401S, P2403S, P2405S

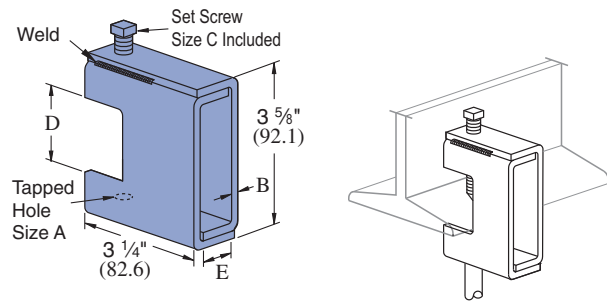

Weld is not continuous it is either 1/4\"/>

Part Number	"A" In	"B" In (mm)	"C" In	"D" In (mm)	"E" In (mm)	Wt/100 pcs Lbs (kg)	Design Load Lbs (kN)
P2398S	1/4 - 20	3.2	3/8 x 2	1 21/32	7/8	109	800
P2401S	3/8 - 16	4.8	1/2 x 2	1 11/16	29/32	156	1,300
P2403S	1/2 - 13	6.4	1/2 x 2	1 11/16	15/16	201	1,900
P2405S	5/8 - 11	7.9	5/8 x 2	1 11/16	19/16	311	2,400

For beams between 3/4\"/>

P1648S THRU P1653S

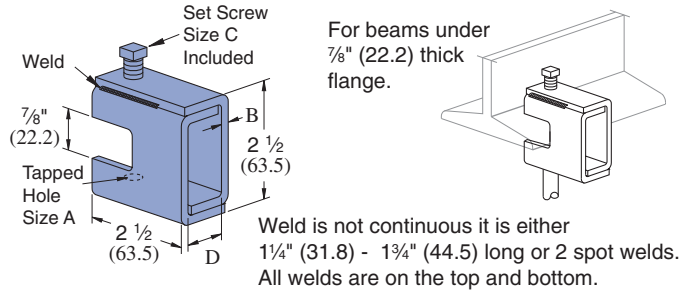

Weld is not continuous it is either 1/4\"/>

Part Number	"A" In	"B" In (mm)	"C" In	"D" In (mm)	Wt/100 pcs Lbs (kg)	Design Load Lbs (kN)
P1648S	1/4 - 20	3.2	3/8 x 1 1/2	7/8	67	650
P1649S	5/16 - 18	3.2	3/8 x 1 1/2	7/8	67	650
P1649AS	3/8 - 16	3.2	3/8 x 1 1/2	7/8	67	650
P1650S	3/8 - 16	4.8	1/2 x 1 1/2	15/16	100	1,100
P1650AS	1/2 - 13	4.8	1/2 x 1 1/2	15/16	100	1,100
P1651S	1/2 - 13	6.4	1/2 x 1 1/2	15/16	130	1,600
P1651AS	5/8 - 11	6.4	1/2 x 1 1/2	15/16	130	1,600
P1652S	5/8 - 11	7.9	5/8 x 1 1/2	15/16	160	2,400
P1653S	3/4 - 10	7.9	5/8 x 1 1/2	19/16	160	2,400

P1654A THRU P1661A

RETAINER STRAP

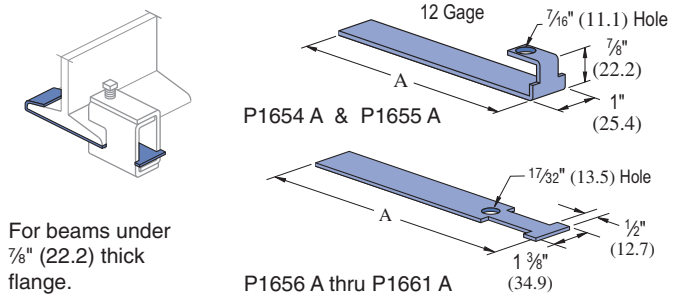

For beams under 7/8\"/>

Strap Part Number	Flange Width In (mm)	"A" In (mm)	Wt/100 pcs Lbs (kg)	Beam Clamp Used With
P1654 A	6 152.4	7 177.8	25 11.3	P2675
P1655 A	9 228.6	10 254.0	34 15.4	P2675
P1656 A	6 152.4	9 228.6	35 15.9	P1648 S Thru P1651 AS, P2398S, P2401S & P2403S
P1657 A	9 228.6	12 304.8	47 21.3	
P1658 A	12 304.8	15 381.0	59 26.8	
P1659 A	6 152.4	9 228.6	33 15.0	P2676
P1660 A	9 228.6	12 304.8	45 20.4	P2676
P1661 A	12 304.8	15 381.0	57 25.9	P2676

Note: When used for mechanical supports, load capacities of brackets and fittings should be in compliance with the American Standard Code for Pressure Piping. Clamps are designed to be used with W, M, S & HP Shape beams, Standard C & Misc. MC Channels, Angles & Structural Tees. Clamps must be used in pairs where indicated. For beam clamps with HG finish, standard hardware is EG finish. For optional stainless steel hardware, please contact the factory for availability.

General Fittings

Strut & Supply, Inc.
28005 W. Commercial Ave. Barrington, IL 60010

Ph: 847.756.4337 Fx: 847.304.1891
email: CustomerService@strutandsupply.com



Telestrut 1 5/8" Channel

Nuts & Hardware

General Fittings

Pipe/Conduit Supports

Electrical Fittings

Unipier® Concrete Inserts

P1271S

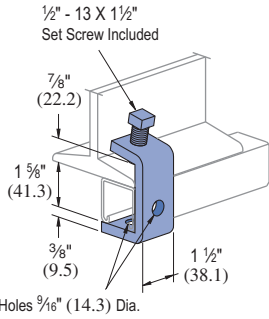

Note: Requires P1010 Channel Nut and bolt.

Design Load Each
500 Lbs (2.22 kN)
Use in Pairs Only

Wt/100 pcs: 95 Lbs (43.1 kg)

P1796S

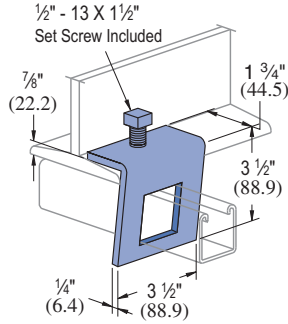

Design Load Each
500 Lbs (2.22 kN)
Use in Pairs Only

Wt/100 pcs: 91 Lbs (41.3 kg)

P2824-6,-9,-12

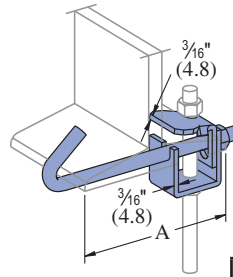

For use with Beams up to 3/4" (19.1) max flange thickness

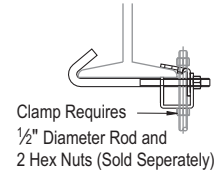

Part Number	"A" In (mm)	Wt/100 pcs Lbs (kg)	Design Load Lbs (kN)
P2824-6	2 1/2 - 6	125	500
	63.5 - 152.4	56.7	2.22
P2824-9	5 1/2 - 9	140	500
	139.7 - 228.6	63.5	2.22
P2824-12	8 1/2 - 12	171	500
	215.9 - 304.8	77.6	2.22

P2785

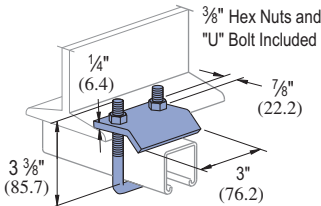

• For use with Beams up to 3/4" (19.1) Flanges and with Channels P1000, P1100, P2000, P3000, P3300, P3301, P4000, P4001, P4100, and P4101.

Design Load Each
1000 Lbs (4.45 kN)
Use in Pairs Only

Wt/100 pcs: 83 Lbs (37.6 kg)

P2786

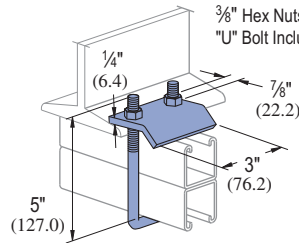

• For use with Beams up to 3/4" (19.1) Flanges and with Channels P1001, P1101, P2001, P3001, P5000, and P5500.

Design Load Each
1000 Lbs (4.45 kN)
Use in Pairs Only

Wt/100 pcs: 92 Lbs (41.7 kg)

P2787

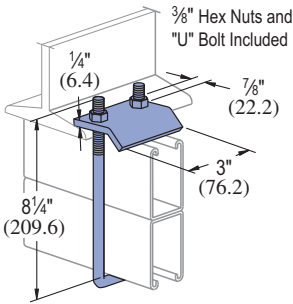

• For use with Beams up to 3/4" (19.1) Flanges and with Channels P5001 and P5501.

Design Load Each
1000 Lbs (4.45 kN)
Use in Pairs Only

Wt/100 pcs: 112 Lbs (50.8 kg)

P2867

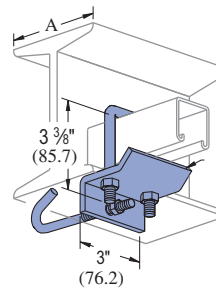

Part Number	Beam Size "A"	Wt/100 pcs Lbs (kg)
P2867	4"-6"	142 (64.4)
P2867-9	6"-9"	151 (68.5)
P2867-12	9"-12"	160 (72.6)
P2867-15	12"-15"	170 (77.1)
P2867-18	15"-18"	179 (81.2)

• Includes: "J" Bolt, "U" Bolt and Hex Nuts.
• For use with Channels P1000, P1100, P2000, P3000, P3300, P3301, P4000, P4001, P4100, and P4101.

P2867A

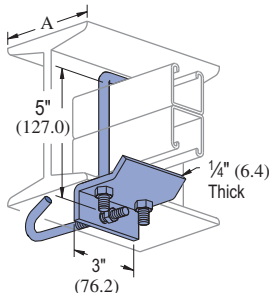

Part Number	Beam Size "A"	Wt/100 pcs Lbs (kg)
P2867A	4"-6"	151 (68.5)
P2867A-9	6"-9"	157 (71.2)
P2867A-12	9"-12"	166 (75.3)
P2867A-15	12"-15"	176 (79.8)
P2867A-18	15"-18"	185 (83.9)

• Includes: "J" Bolt, "U" Bolt and Hex Nuts.
• For use with Channel P1001, P1101, P2001, P3001, P5000, and P5500.

P2867B

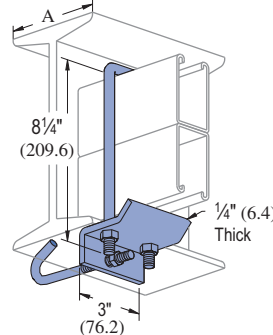

Part Number	Beam Size "A"	Wt/100 pcs Lbs (kg)
P2867B	4"-6"	161 (73.0)
P2867B-9	6"-9"	167 (75.7)
P2867B-12	9"-12"	176 (79.8)
P2867B-15	12"-15"	186 (84.4)
P2867B-18	15"-18"	195 (88.5)

• Includes: "J" Bolt, "U" Bolt and Hex Nuts.
• For use with Channel P5001, and P5501.

Note: When used for mechanical supports, load capacities of brackets and fittings should be in compliance with the American Standard Code for Pressure Piping. Clamps are designed to be used with W, M, S & HP Shape beams, Standard C & Misc. MC Channels, Angles & Structural Tees. Clamps must be used in pairs where indicated. For beam clamps with HG finish, standard hardware is EG finish. For optional stainless steel hardware, please contact the factory for availability.

P2868

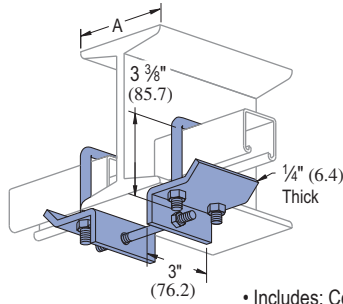

Part Number	Beam Size "A"	Wt/100 pcs Lbs (kg)
P2868	4"-6"	282 (127.9)
P2868-9	6"-9"	289 (131.1)
P2868-12	9"-12"	296 (134.3)
P2868-15	12"-15"	304 (137.9)
P2868-18	15"-18"	311 (141.1)

- Includes: Center Rod, "U" Bolts and Hex Nuts.
- For use with Channels P1000, P1100, P2000, P3000, P3300, P3301, P4000, P4001, P4100, and P4101.

P2868A

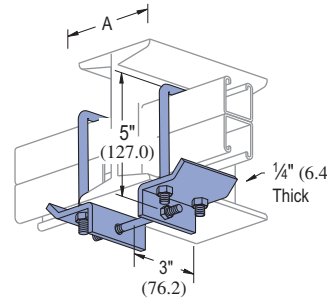

Part Number	Beam Size "A"	Wt/100 pcs Lbs (kg)
P2868A	4"-6"	300 (136.1)
P2868A-9	6"-9"	307 (139.3)
P2868A-12	9"-12"	314 (142.2)
P2868A-15	12"-15"	322 (146.1)
P2868A-18	15"-18"	329 (149.2)

- Includes: Center Rod, "U" Bolts and Hex Nuts.
- For use with Channels P1001, P1101, P2001, P3001, P5000, and P5500.

P2868B

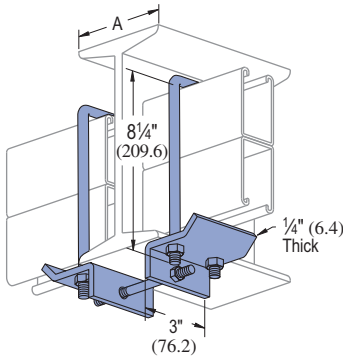

Part Number	Beam Size "A"	Wt/100 pcs Lbs (kg)
P2868B	4"-6"	320 (145.1)
P2868B-9	6"-9"	327 (148.3)
P2868B-12	9"-12"	334 (151.5)
P2868B-15	12"-15"	342 (155.1)
P2868B-18	15"-18"	349 (153.3)

- Includes: Center Rod, "U" Bolts and Hex Nuts.
- For use with Channels P5001, and P5501.

P2894

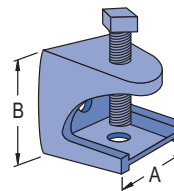

Material: Malleable Iron
 7/8" Maximum Flange Thickness
 Note: Tapped Hole on Top and Bottom

Part Number	Rod Size In	"A" In (mm)	"B" In (mm)	Load Ratings Lbs (kN)	Wt/100 pcs Lbs (kg)
P2894-25	1/4	1 1/8	1 1/4	150	23
		28.6	31.8	.67	10.4
P2894-37	3/8	2	2	350	95
		50.8	50.8	1.56	43.1
P2894-50	1/2	2 5/8	2 1/2	400	195
		66.7	63.5	1.78	88.5

P2893

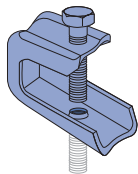

Material: Steel
 Use With: 1/4" rod
 Load Rating: 75 lbs. (.33 kN)

Wt/100 pcs: 14 lbs. (6.4 kg)

P2895

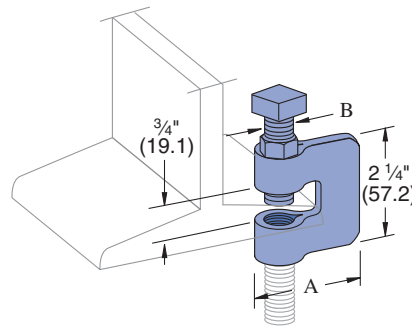

Material: Steel

Part Number	Rod Size In	"A" In (mm)	"B" In (mm)	Load Ratings Lbs (kN)	Wt/100 pcs Lbs (kg)
P2895-37	3/8	2 5/16	3/8	330	35
		58.7	9.5	1.47	15.9
P2895-50	1/2	2 1/4	1/2	380	41
		57.2	12.7	1.69	18.6
P2895-62	5/8	2 3/8	5/8	450	67
		60.3	15.9	2.00	30.4
P2895-75	3/4	2 1/4	1/2	500	72
		57.2	12.7	2.22	32.7

P2896

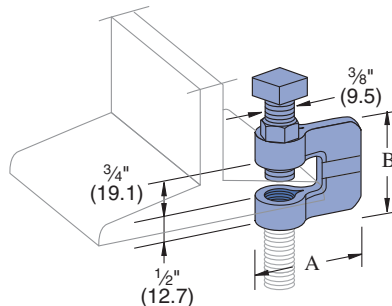

Material: Malleable Iron,
 Steel Set Screw

Part Number	Rod Size In	"A" In (mm)	"B" In (mm)	Load Ratings Lbs (kN)	Wt/100 pcs Lbs (kg)
P2896-37	3/8	1 11/16	1 1/4	400	38
		42.9	44.5	1.78	17.2
P2896-50	1/2	1 23/32	1 3/4	400	52
		43.7	44.5	1.78	23.6
P2896-62	5/8	1 5/16	2	450	68
		49.2	50.8	2.00	30.8
P2896-75	3/4	2 1/32	2	600	128
		51.6	50.8	2.67	58.1

Standard Dimensions for 1 1/8" (41mm) width series channel fittings (Unless Otherwise Shown on Drawing)

Hole Diameter: 3/16" (14mm); Hole Spacing - From End: 1 1/16" (21mm); Hole Spacing - On Center: 1 1/8" (48mm); Width: 1 1/8" (41mm); Thickness: 1/4" (6mm)

Note: When used for mechanical supports, load capacities of brackets and fittings should be in compliance with the American Standard Code for Pressure Piping. Clamps are designed to be used with W, M, S & HP Shape beams, Standard C & Misc. MC Channels, Angles & Structural Tees. Clamps must be used in pairs where indicated. For beam clamps with HG finish, standard hardware is EG finish. For optional stainless steel hardware, please contact the factory for availability.



P1386

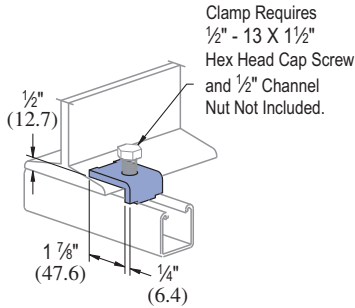

Channel Style	Design Load Each (Use in Pairs Only) Lbs (kN)
P1000	600 2.67
P1100	500 2.22
P2000	450 2.00

Wt/100 pcs: 27 Lbs (12.2 kg)

P1379S

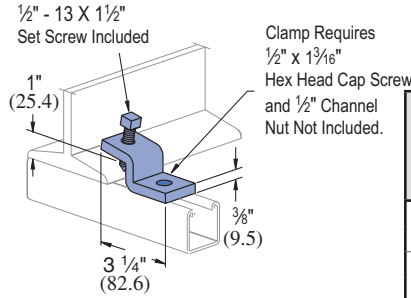

Channel Style	Design Load Each (Use in Pairs Only) Lbs (kN)
P1000	600 2.67
P1100	500 2.22
P2000	450 2.00

Wt/100 pcs: 75 Lbs (34.0kg)

P1272S, P1985S, P1986S

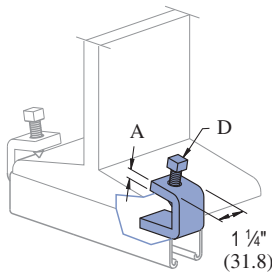

Part Number	"A" In (mm)	Flange Thickness In (mm)	"D" Set Screw Included	Wt/100 pcs Lbs (kg)	Design Load Per Pair (Use in Pairs Only) Lbs (kN)
P1272S	1/4 6.4	Up to 3/4 Up to 19.1	3/8-16 x 1 1/2	39 17.7	450 2.00
P1985S	3/8 9.5	Up to 3/4 Up to 19.1	1/2-13 x 1 1/2	62 28.1	1,000 4.45
P1986S	3/8 9.5	7/8 to 2 22.2 - 50.8	1/2-13 x 1 1/2	74 33.6	900 4.00

P3087

COLUMN INSERT

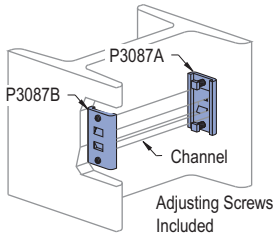

Channel Part Number	Design Pull Out Load Lbs (kN)	Design Slip Load Lbs (kN)
P1000	1,000 4.45	800 3.56
P1100	700 3.34	500 2.22
P2000	500 2.22	300 1.33

Safety factor of 3.

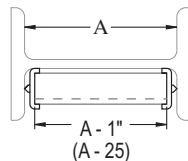

Wt/100 pcs: 136 Lbs (61.7 kg)

- Adjusting Screws Included.
- Unistrut channel not included.
- Part number P3087 consists of:
 - (1) piece P3087A,
 - (1) piece P3087B and
 - (2) set screws, 3/8" Dia.

P3088

COLUMN INSERT

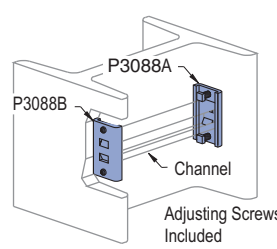

Channel Part Number	Design Pull Out Load Lbs (kN)	Design Slip Load Lbs (kN)
P3300	1,000 4.45	800 3.56
P4100	700 3.11	500 2.22
P4000	500 2.22	300 1.33

Safety factor of 3.

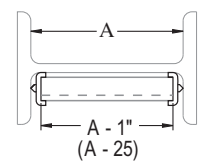

Wt/100 pcs: 120 Lbs (54.4 kg)

- Adjusting Screws Included.
- Unistrut channel not included.
- Part number P3088 consists of:
 - (1) piece P3088A,
 - (1) piece P3088B and
 - (2) set screws, 3/8" Dia.

PLLC025

FLANGE CLAMP

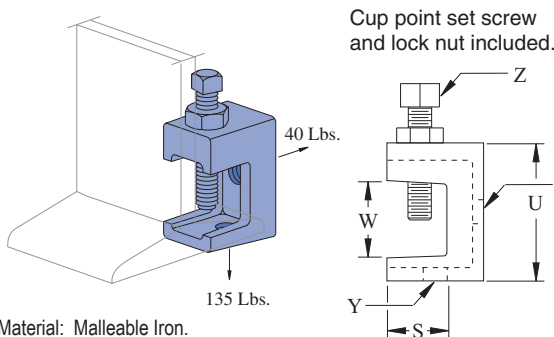

Set Screw Torque = 3 Ft-Lb
Lock Nut Torque = 3.5 Ft-Lb

X, Y are threaded holes.

Part Number	Rod Size	"Z" Set Screw Size	Wt/100 pcs Lbs (kg)
PLLC025	1/4"	1/4"	16 (7.3)

Part Number	"S" In (mm)	"T" In (mm)	"U" In (mm)	"V", "W" In (mm)	"X", "Y" In
PLLC025	5/8 15.9	1 25.4	1 1/16 36.5	3/4 19.1	1/4 X 20

Material: Malleable Iron.

Note: When used for mechanical supports, load capacities of brackets and fittings should be in compliance with the American Standard Code for Pressure Piping. Clamps are designed to be used with W, M, S & HP Shape beams, Standard C & Misc. MC Channels, Angles & Structural Tees. Clamps must be used in pairs where indicated. For beam clamps with HG finish, standard hardware is EG finish. For optional stainless steel hardware, please contact the factory for availability.

PFL037 THRU PFL050T

FLANGE CLAMP

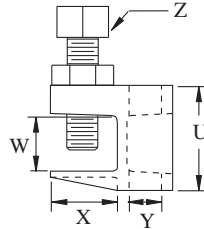
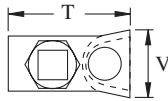
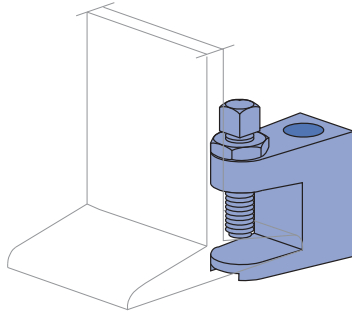

Material: Malleable Iron.

Cup point set screw and lock nut included.

Set Screw Torque = 6 Ft-Lb
Lock Nut Torque = 16 Ft-Lb

Safety Factor: 4

Part Number	Type of Hole	Rod Size	"Z" Set Screw Size	Wt/100 pcs Lbs (kg)	Max. Allowable Load Lbs (kN)
PFL037	Clear	3/8"	3/8"	28 (12.7)	540 (2.40)
PFL037T	Tapped	3/8"	3/8"	28 (12.7)	540 (2.40)
PFL050	Clear	1/2"	3/8"	40 (18.1)	700 (3.11)
PFL050T	Tapped	1/2"	3/8"	40 (18.1)	700 (3.11)

Part Number	Dimensions					
	"T" In (mm)	"U" In (mm)	"V" In (mm)	"W" In (mm)	"X" In (mm)	"Y" In (mm)
PFL037	1 1/16	1 9/16	7/8	3/4	1	7/16
	42.9	39.7	22.2	19.1	25.4	11.1
PFL037T	1 1/16	1 9/16	7/8	3/4	1	3/8 Tapped Hole
	42.9	39.7	22.2	19.1	25.4	
PFL050	2	2 3/32	1	2 9/32	1 3/32	9/16
	50.8	43.7	25.4	23.0	27.8	14.3
PFL050T	2	2 3/32	1	2 9/32	1 3/32	1/2 Tapped Hole
	50.8	43.7	25.4	23.0	27.8	

PLF3037 THRU PLF3075

FLANGE CLAMP

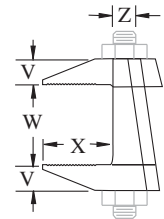
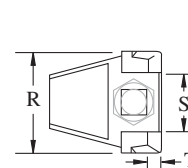
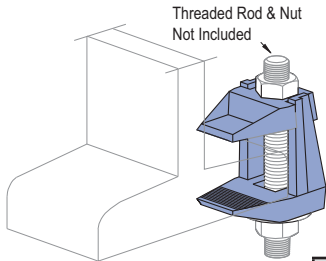

Safety Factor: 4

Material: Malleable Iron.

Part Number	Rod Size	Wt/100 pcs Lbs (kg)	Max. Allowable Load Lbs (kN)	Torque Ft-Lbs
PLF3037	3/8"	53	270	15
PLF3050	1/2"	91	450	29
PLF3062	5/8"	186	900	69
PLF3075	3/4"	334	1,350	130

Part Number	Dimensions					
	"X" In (mm)	"W" In (mm)	"V" In (mm)	"T" In (mm)	"R" In (mm)	"S" In (mm)
PLF3037	1	0 - 1 1/16	3/8	9/32	1 1/2	7/8
	25.4	0 - 30.2	9.5	7.1	38.1	22.2
PLF3050	1 3/8	0 - 1 9/16	1/2	1 1/32	1 5/16	1 5/32
	34.9	0 - 39.7	12.7	8.7	49.2	29.4
PLF3062	1 13/16	0 - 2 3/16	5/8	1/2	2 1 1/2	1 7/16
	46.0	0 - 55.6	15.9	12.7	59.5	36.5
PLF3075	2 3/16	0 - 1 3/4	3/4	5/8	3	1 3/4
	55.6	0 - 44.5	19.1	15.9	76.2	44.5

PLF9037 THRU PLF9100

FLANGE CLAMP

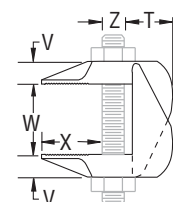
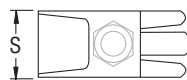
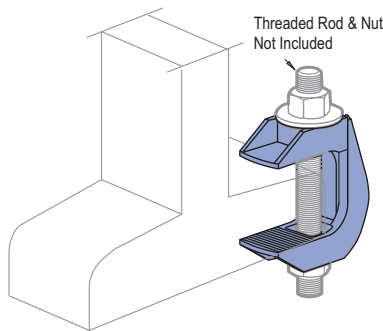

Part Number	Rod Size	Wt/100 pcs Lbs (kg)	Max. Allowable Load Lbs (kN)	Torque Ft-Lbs	"X"	"W"	"V"	"T"	"S"
					In (mm)	In (mm)	In (mm)	In (mm)	In (mm)
PLF9037	3/8"	55	440	15	1	3/4 - 1 1/16	1/2	3/4	1
					25.4	19.1 - 42.9	12.7	19.1	25.4
PLF9050	1/2"	122	630	29	1 1/8	1 - 2 3/8	2 1/32	1 5/16	1 1/8
					34.9	25.4 - 60.3	16.7	23.8	30.2
PLF9062	5/8"	200	1,260	69	1 11/16	1 1/8 - 2 3/4	1 3/16	1 1/8	1 3/8
					42.9	28.6 - 69.9	20.6	28.6	34.9
PLF9075	3/4"	367	1,880	131	2	1 1/4 - 3 1/4	1	1 1/8	1 3/4
					50.8	31.8 - 82.6	25.4	34.9	44.5
PLF9100	1"	1,101	3,150	173	3	1 1/4 - 3 3/4	1 1/2	2 3/16	2 1/2
					76.2	44.9 - 95.3	38.1	55.6	63.5

Material: Malleable Iron.

Safety Factor: 4

Note: When used for mechanical supports, load capacities of brackets and fittings should be in compliance with the American Standard Code for Pressure Piping. Clamps are designed to be used with W, M, S & HP Shape beams, Standard C & Misc. MC Channels, Angles & Structural Tees. Clamps must be used in pairs where indicated. For beam clamps with HG finish, standard hardware is EG finish. For optional stainless steel hardware, please contact the factory for availability.

General Fittings



P1834

CHANNEL TROLLEY SUPPORT

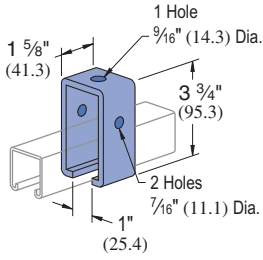

Requires 3/8" x 2 1/2" Bolt and 3/8" Nut (not included)

Design Load	
1200 Lbs (5.34 kN)	

Wt/100 pcs: 102 Lbs (46.3 kg)

P1834A

CHANNEL TROLLEY SUPPORT

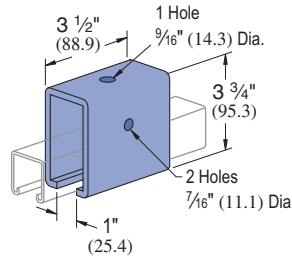

Requires 3/8" x 2 1/2" Bolt and 3/8" Nut (not included)

Design Load	
2500 Lbs (11.12 kN)	

Wt/100 pcs: 220 Lbs (99.8 kg)

P2749*, P2749N†

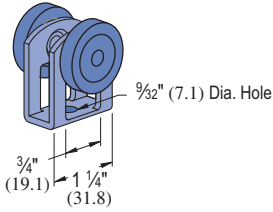

Clevis Material: 12 gauge.

*Wheel bearings are stainless steel, and should not be lubricated.

† "N" indicates acetal wheels.

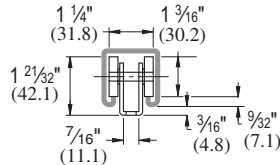

Part Number	Design Load Lbs (kN)	Wt/100 pcs Lbs (kg)
P2749	50 .22	21 9.5
P2749N	10 .04	13 5.9

P2751*, P2751 N†

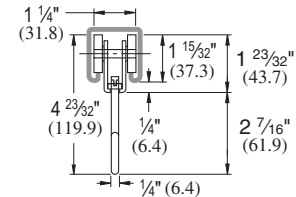
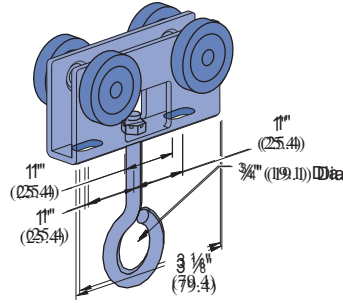

Part Number	Design Load Lbs (kN)	Wt/100 pcs Lbs (kg)
P2751	100 .44	63 28.6
P2751N	20 .09	40 18.1

Clevis Material: 12 gauge.

*Wheel bearings are stainless steel, and should not be lubricated.

† "N" indicates acetal wheels.

P2750*, P2750N†

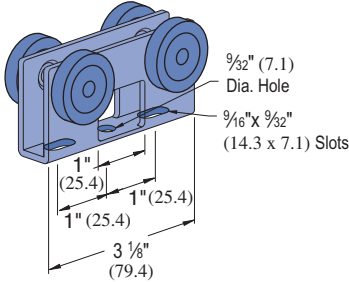

Clevis Material: 12 gauge.

*Wheel bearings are stainless steel, and should not be lubricated.

† "N" indicates acetal wheels.

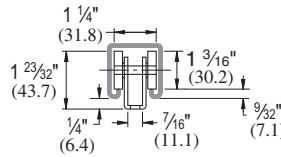

Part Number	Design Load Lbs (kN)	Wt/100 pcs Lbs (kg)
P2750	100 .44	55 24.9
P2750N	20 .09	32 14.5

P2950

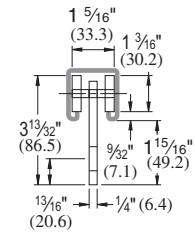
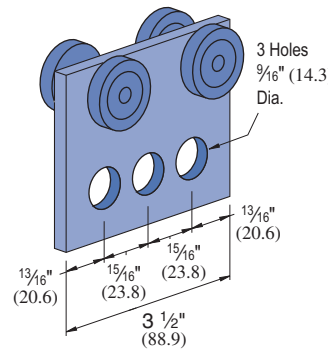

Wheel bearings are stainless steel. Do not lubricate.

Design Load In P1000 Lbs (kN)		
FPM	RPM	Lbs (kN)
180	600	300
90	300	450
30	100	600
		2.67

Wt/100 pcs: 110 Lbs (49.9 kg)

Standard Dimensions for 1 5/8" (41mm) width series channel fittings (Unless Otherwise Shown on Drawing)

Hole Diameter: 9/16" (14mm); Hole Spacing - From End: 1 3/16" (21mm); Hole Spacing - On Center: 1 7/8" (48mm); Width: 1 5/8" (41mm); Thickness: 1/4" (6mm)

P2354 R-L, P2355 R-L

REEL RACK SUPPORTS FOR 1 1/4" & 2" PIPE

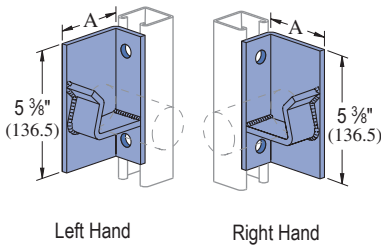

Vertical Channel Part No.	Gauge	Max. Allowable Load Lbs (kN)
P1000	12	3,000 (13.34)
P1100	14	2,000 (8.90)
P2000	16	2,000 (8.90)

Part Number	"A" In (mm)	Std. Pipe Size In (mm)	Wt/100 pcs Lbs (kg)
P2354 R-L	3	1 1/4	220
	76.2	31.8	99.8
P2355 R-L	3 3/8	2	252
	92.1	50.8	114.3

P1204 THRU P1208

WALL LADDER BRACKET

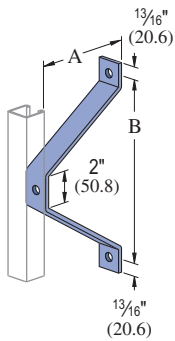

Part Number	"A" In (mm)	"B" In (mm)	Wt/100 pcs Lbs (kg)
P1204	2 1/8	6	113
	60.3	152.4	51.3
P1205	4 1/8	8	164
	111.1	203.2	74.4
P1206	6 1/8	10	216
	161.9	254.0	98.0
P1207	8 1/8	12	267
	212.7	304.8	121.1
P1208	10 1/8	14	318
	263.5	355.6	144.2

P2454

DOUBLE PIPE AXLE SUPPORT

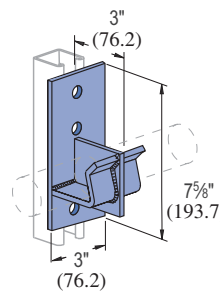

Load Rating 4,000 Lbs (17.79 kN)

For 1 1/4" (31.8) Standard Pipe

Wt/100 pcs: 310 Lbs (140.6 kg)

P1201, P1202, P1203

LADDER RUNG

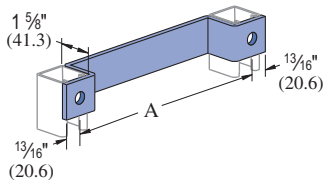

Part Number	"A" In (mm)	Wt/100 pcs Lbs (kg)
P1201	12	186
	304.8	84.4
P1202	15	221
	381.0	100.2
P1203	18	254
	457.2	115.2

P2470-50, -75, -100

PIPE COUPLING FITTING

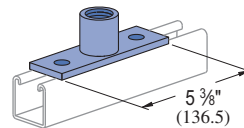

Pipe Coupling		
Part Number	Size In	Wt/100 pcs Lbs (kg)
P2470-50	1/2	77 (34.9)
P2470-75	3/4	93 (42.2)
P2470-100	1	103 (46.7)

P1944

45° (.25π) STAIR TREAD SUPPORT

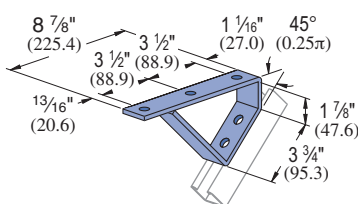

Wt/100 pcs: 220 Lbs (99.8 kg)

P2655

37 1/2° (.21π) STAIR TREAD SUPPORT

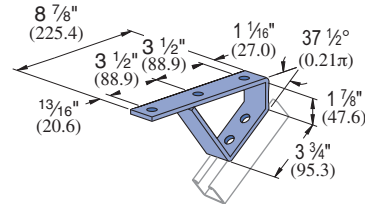

Wt/100 pcs: 213 Lbs (96.6 kg)

Standard Dimensions for 1 1/8" (41mm) width series channel fittings (Unless Otherwise Shown on Drawing)

Hole Diameter: 3/16" (14mm); Hole Spacing - From End: 1 3/16" (21mm); Hole Spacing - On Center: 1 1/8" (48mm); Width: 1 1/8" (41mm); Thickness: 1/4" (6mm)

Note: When used for mechanical supports, load capacities of brackets and fittings should be in compliance with the American Standard Code for Pressure Piping.



P1843 ADJ. HINGE CONNECTION

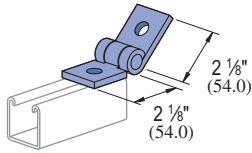

Wt/100 pcs: 68 Lbs (30.8 kg)

P1354A ADJ. HINGE CONNECTION

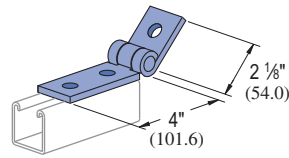

Wt/100 pcs: 89 Lbs (40.4 kg)

P1354 ADJ. HINGE CONNECTION

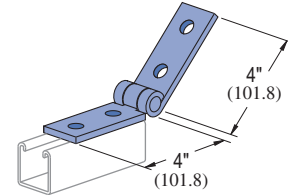

Wt/100 pcs: 109 Lbs (49.4 kg)

SPF® 100

SEISMIC PIVOT FITTINGS

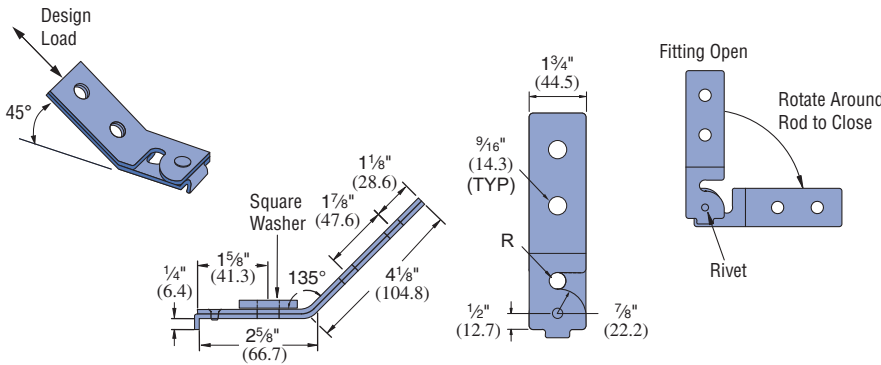

Part Number	Rod Size In (mm)	"R" - Hole Diameter In (mm)	Design Load Lbs (KN)
SPF 100-037	3/8 9.5	7/16 11.1	1,400 6.23
SPF 100-050	1/2 12.7	9/16 14.3	2,100 9.34
SPF 100-062	5/8 15.9	1 1/16 17.5	2,100 9.34
SPF 100-075	3/4 19.1	1 3/16 20.6	2,400 10.68

Safety Factor = 3
FINISH
Electro-galvanized (EG), conforming to ASTM B633 Type III SC1.

Notes:

- Design load is limited to slip capacity of a channel nut at hole "R".
- Allowable loads have been determined by the manufacturers testing, analysis and technical specifications.
- For retrofit application, engineer of record must verify.
- Square washer provided with fitting.
- When a hanger rod is thru-bolted (in lieu of channel nut installation), higher transverse loads may be transmitted due to the higher allowed rod shear loads compared to channel nut slip values. This higher load may be used with verification through engineering calculations.

SPF® 200

ADJUSTABLE SEISMIC PIVOT FITTINGS

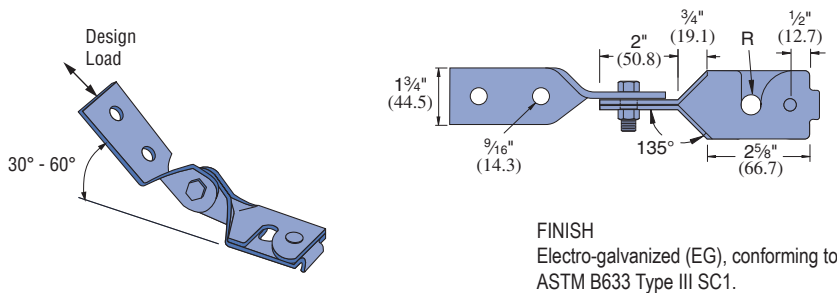

FINISH
Electro-galvanized (EG), conforming to ASTM B633 Type III SC1.

Part Number	Rod Size In (mm)	"R" - Hole Diameter In (mm)	Design Load Lbs (KN)
SPF 200-037	3/8 9.5	7/16 11.1	1,400 6.23
SPF 200-050	1/2 12.7	9/16 14.3	2,100 9.34
SPF 200-062	5/8 15.9	1 1/16 17.5	2,100 9.34
SPF 200-075	3/4 19.1	1 3/16 20.6	2,400 10.68

Safety Factor = 3.0

Notes:

- Design load is limited to slip capacity of a channel nut at hole "R".
- Allowable loads have been determined by the manufacturers testing, analysis and technical specifications at 45° from horizontal.
- For retrofit application, engineer of record must verify.
- Square washer provided with fitting.
- When a hanger rod is thru-bolted (in lieu of channel nut installation), higher transverse loads may be transmitted due to the higher allowed rod shear loads compared to channel nut slip values. This higher load may be used with verification through engineering calculations.

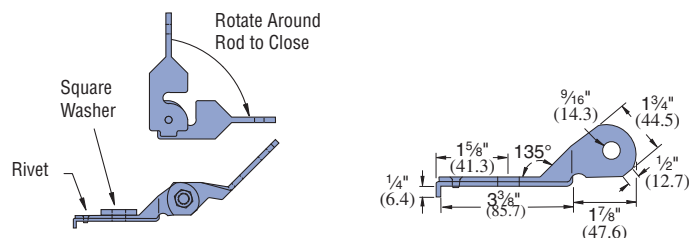

SPF® 300

SEISMIC PIVOT FITTINGS

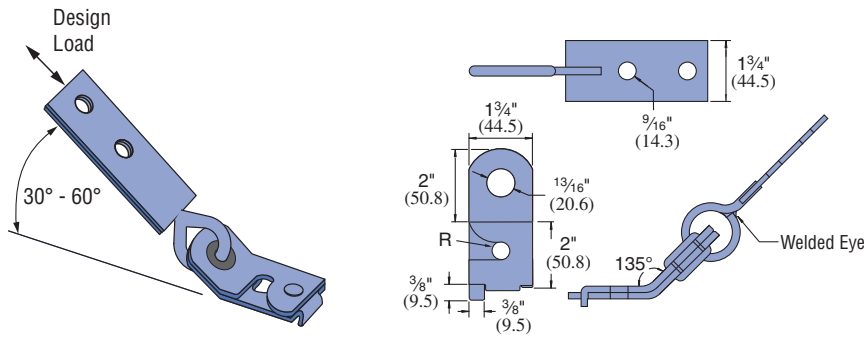

Part Number	Rod Size In (mm)	"R" - Hole Diameter In (mm)	Design Load Lbs (kN)
SPF 300-037	3/8 (9.5)	7/16 (11.1)	1,400 (6.23)
SPF 300-050	1/2 (12.7)	9/16 (14.3)	2,100 (9.34)
SPF 300-062	5/8 (15.9)	1 1/16 (17.5)	2,100 (9.34)
SPF 300-075	3/4 (19.1)	1 3/16 (20.6)	2,400 (10.68)

Safety Factor = 3.0
 FINISH
 Electro-galvanized (EG), conforming to
 ASTM B633 Type III SC1.

Notes:

1. Design load is limited to slip capacity of a channel nut at hole "R".
2. Allowable loads have been determined by the manufacturers testing, analysis and technical specifications at 45° from horizontal.
3. For retrofit application, engineer of record must verify.
4. Square washer provided with fitting.
5. When a hanger rod is thru-bolted (in lieu of channel nut installation), higher transverse loads may be transmitted due to the higher allowed rod shear loads compared to channel nut slip values. This higher load may be used with verification through engineering calculations.



SPF® 400

SEISMIC PIVOT FITTINGS

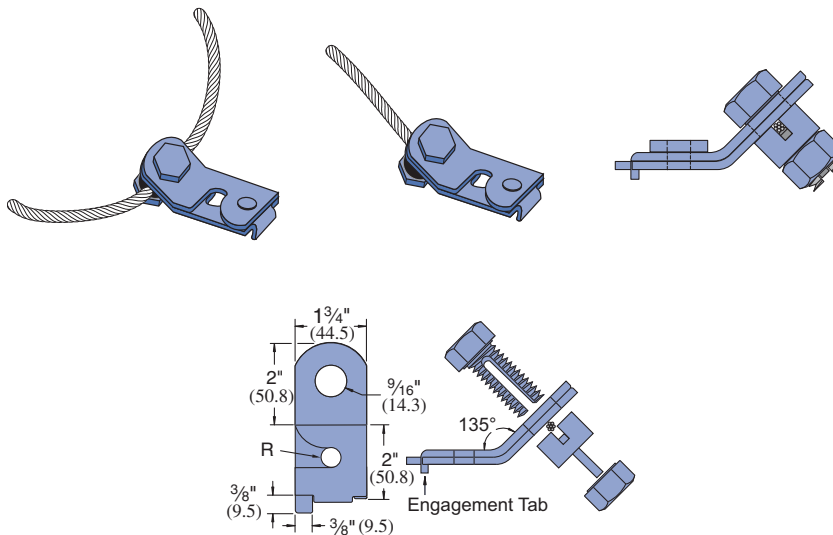

Part Number	Rod Size In (mm)	"R" - Hole Diameter In (mm)
SPF 400-037	3/8 (9.5)	7/16 (11.1)
SPF 400-050	1/2 (12.7)	9/16 (14.3)
SPF 400-062	5/8 (15.9)	1 1/16 (17.5)
SPF 400-075	3/4 (19.1)	1 3/16 (20.6)

FINISH
 Electro-galvanized (EG), conforming to
 ASTM B633 Type III SC1.

Wire Rope Diameter In (mm)	Horizontal Design Load		
	4-Way Splayed		Single Cable Transverse
	Transverse lbs (kN)	Longitudinal lbs (kN)	lbs (kN)
3/16	1050	1116	650
4.8	4.67	4.96	2.89

Notes:

1. Allowable loads have been determined by the manufacturers testing, analysis and technical specifications.
2. Galvanized wire rope, 7 x 19 IWSC, RHRL (Prestretched).
3. Torque on nut/spacer: 50 ft-lbs.
4. Safety Factor of 3 for prestretched cable..

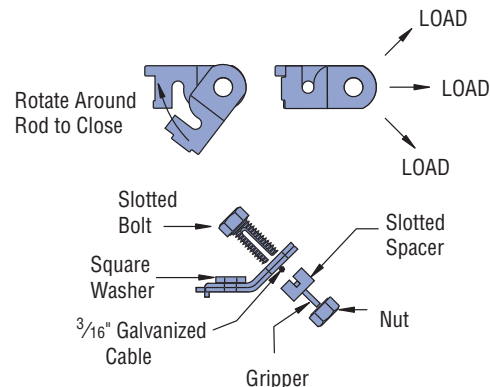



SEISMIC PIVOT FITTINGS

LS 410

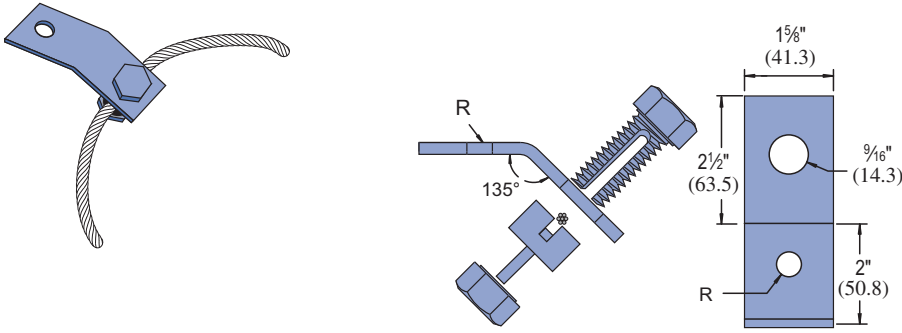

Part Number	Anchor Size In (mm)	"R" - Hole Diameter In (mm)
LS 410-037	3/8 9.5	7/16 11.1
LS 410-050	1/2 12.7	9/16 14.3
LS 410-062	5/8 15.9	11/16 17.5
LS 410-075	3/4 19.1	13/16 20.6

FINISH

Electro-galvanized (EG), conforming to ASTM B633 Type III SC1.

Note:

1. Allowable loads have been determined by the manufacturers testing, analysis and technical specifications.
2. For retrofit application, engineer of record must verify.
3. Torque on nut/spacer: 50 ft-lbs.
4. Square washer provided with fitting.
5. Loads are the same as the SPF 400

LS 500

SEISMIC PIVOT FITTINGS

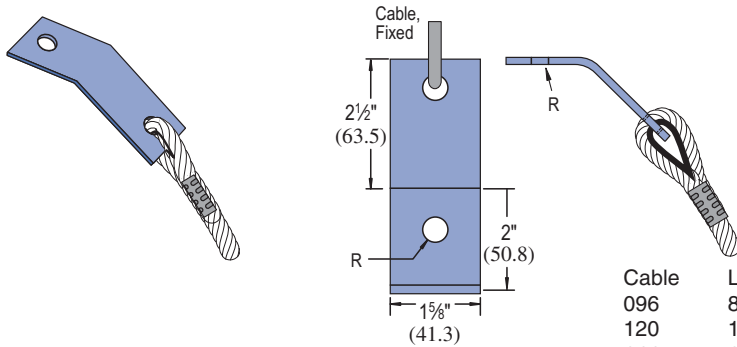

Example
LS500-037-096

┌ Cable Length
├ Anchor Size
└ Fitting Number

Cable	Length
096	8' (2.4M)
120	10' (3.0M)
144	12' (3.6M)
180	15' (4.5M)
240	20' (6.1M)
300	25' (7.6M)
360	30' (9.1M)
480	40' (12.2M)

Part Number	Anchor Size In (mm)	"R" - Hole Diameter In (mm)
LS 500-037	3/8 9.5	7/16 11.1
LS 500-050	1/2 12.7	9/16 14.3
LS 500-062	5/8 15.9	11/16 17.5
LS 500-075	3/4 19.1	13/16 20.6

FINISH

Electro-galvanized (EG), conforming to ASTM B633 Type III SC1.

Note:

1. Allowable loads have been determined by the manufacturers testing, analysis and technical specifications.
2. For retrofit application, engineer of record must verify.
3. Square washer provided with fitting.
4. Loads are the same as the SPF 400